

virtuafit

iConsole FDR 2.1 Ergometer Crosstrainer

User Manual

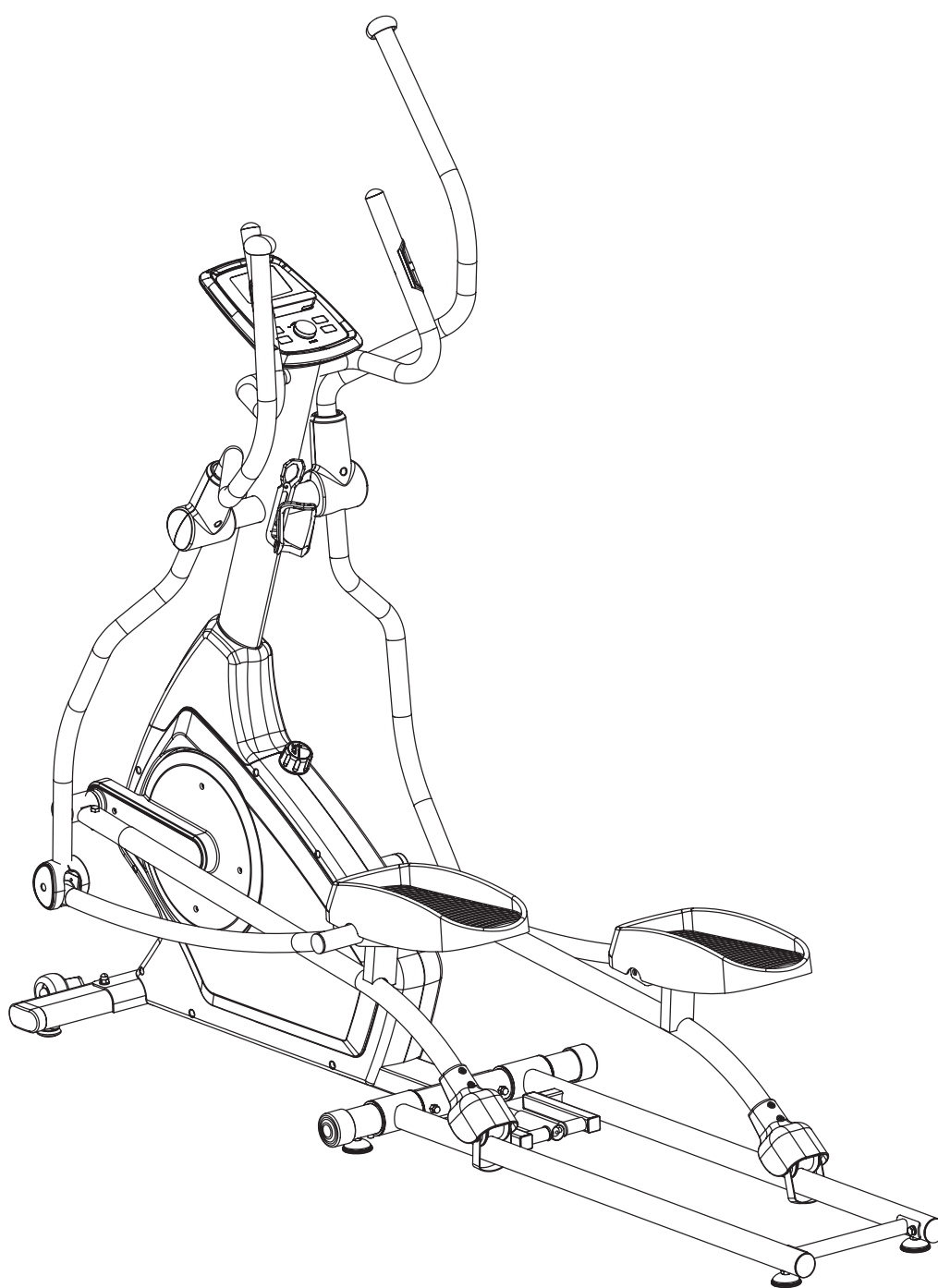

Safety Instructions	3
Checklist	4
Assembly Instructions	5-12
Folding Instructions	13
Maintenance	14
Computer Manual	15-21
Training using an app	22
Exploded Drawing	23
Parts List	24-31

WARNING: BEFORE YOU BEGIN YOUR WORKOUT, WE RECOMMEND THAT YOU FIRST CONTACT YOUR HEALTH SPECIALIST, ESPECIALLY FOR PEOPLE OVER 35 OR PEOPLE WHO ALREADY SUFFER FROM HEALTH PROBLEMS. WE ARE NOT LIABLE FOR ACCIDENTS IF YOU DO NOT FOLLOW OUR INSTRUCTIONS.

ATTENTION

- The crosstrainer is only made for home use and is suitable for users up to 155kg.
- Carefully follow the steps of assembly.
- Use only original parts that are supplied.
- After delivery, check everything with the parts list before you start assembling.
- Only use suitable tools for assembly and ask for help where necessary.
- Place the crosstrainer on a flat surface and a stiff surface. Use in damp rooms is not recommended.
- Check all parts for tightness before you train for the first time. We also recommend checking the parts every the parts every month. Replace broken parts immediately and do not use the crosstrainer if you have not yet replaced the part. Only use original spare parts for repair. Ask your dealer for advice on repairs.
- Avoid using aggressive cleaning agents when cleaning the crosstrainer.
- Start training only after the cross trainer has been fully assembled and checked.
- Be aware that all adjustable parts have a maximum number of settings to which they can be adjusted.
- The crosstrainer is made for adults. Make sure that children only use it when accompanied by an adult.
- Inform users of potential danger, watch out for moving parts during use.

Warning: improper / excessive training can cause injuries.

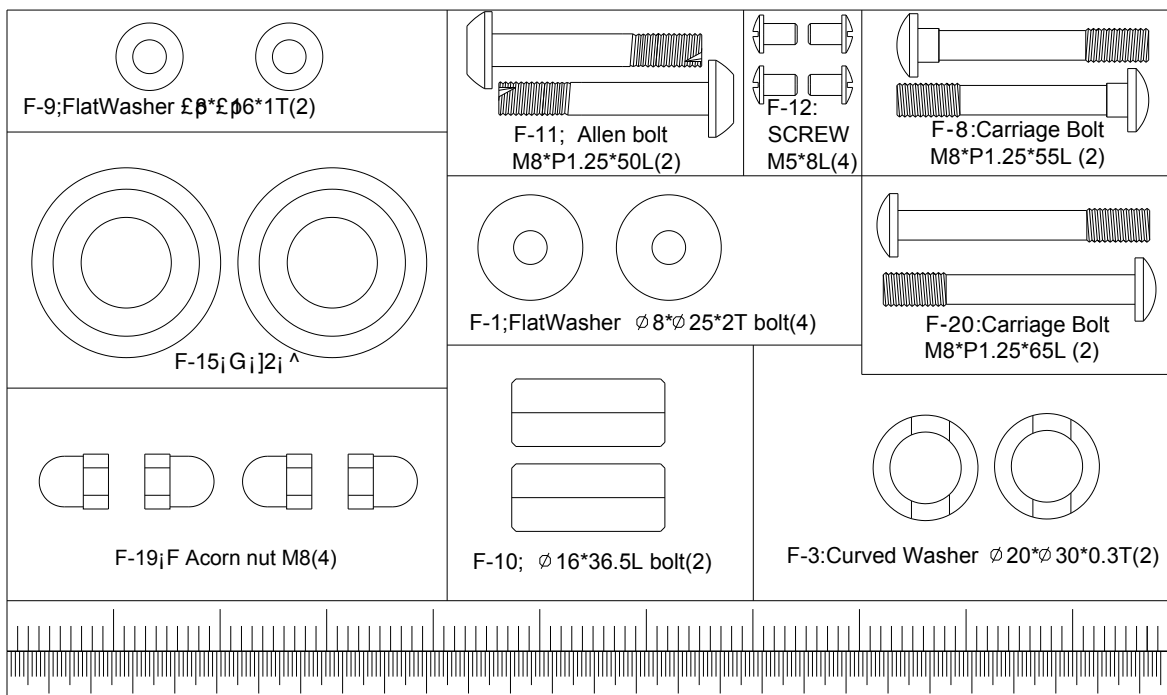
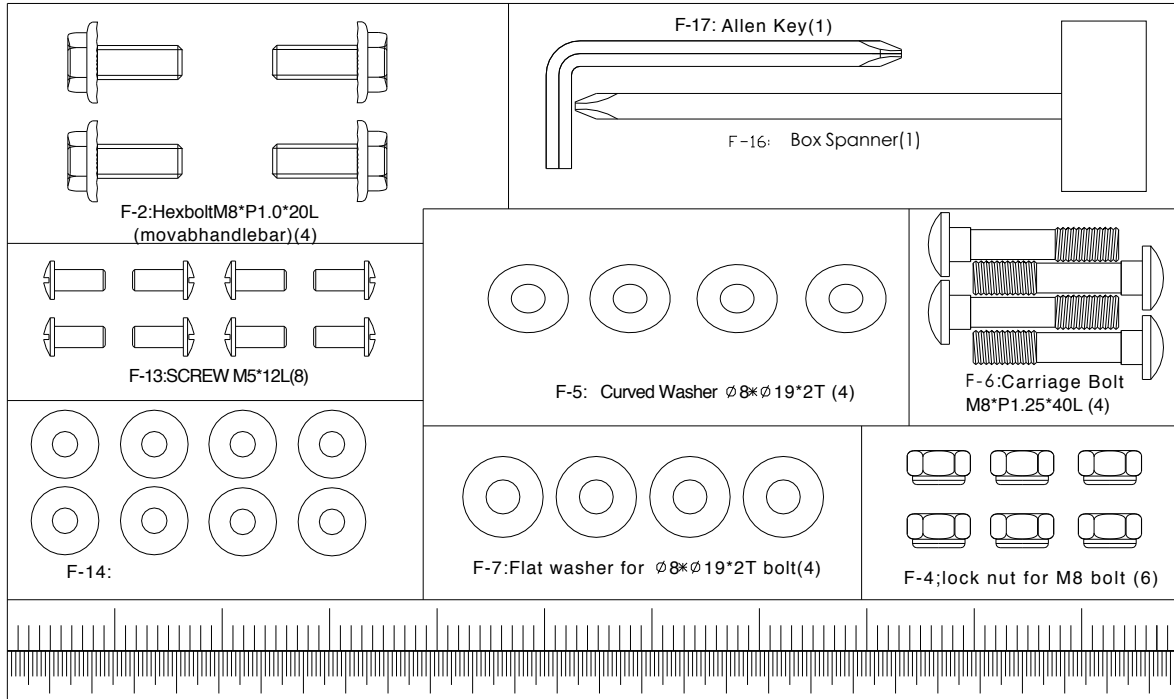

Missing parts: If you think you are missing certain parts in your package, carefully check the styrofoam and the device yourself. Some parts (bolts, screws, etc.) are already attached to / in the device.

Error message: Make sure that all cables are carefully attached. The aluminum legs are very sensitive and should remain straight. Do you get an error message after the installation of your cross trainer? Then you should bend these aluminum feet straight again, this may cause the error message to disappear.

Transport wheels: Make sure that the transport wheels are attached to the front of the device.

Allen screws: In the uprights of cross trainers are hex bolts, make sure that the Allen key is firmly in the bolt before you apply force to the key. In this way you prevent the head of the socket head from being turned

STEP 1

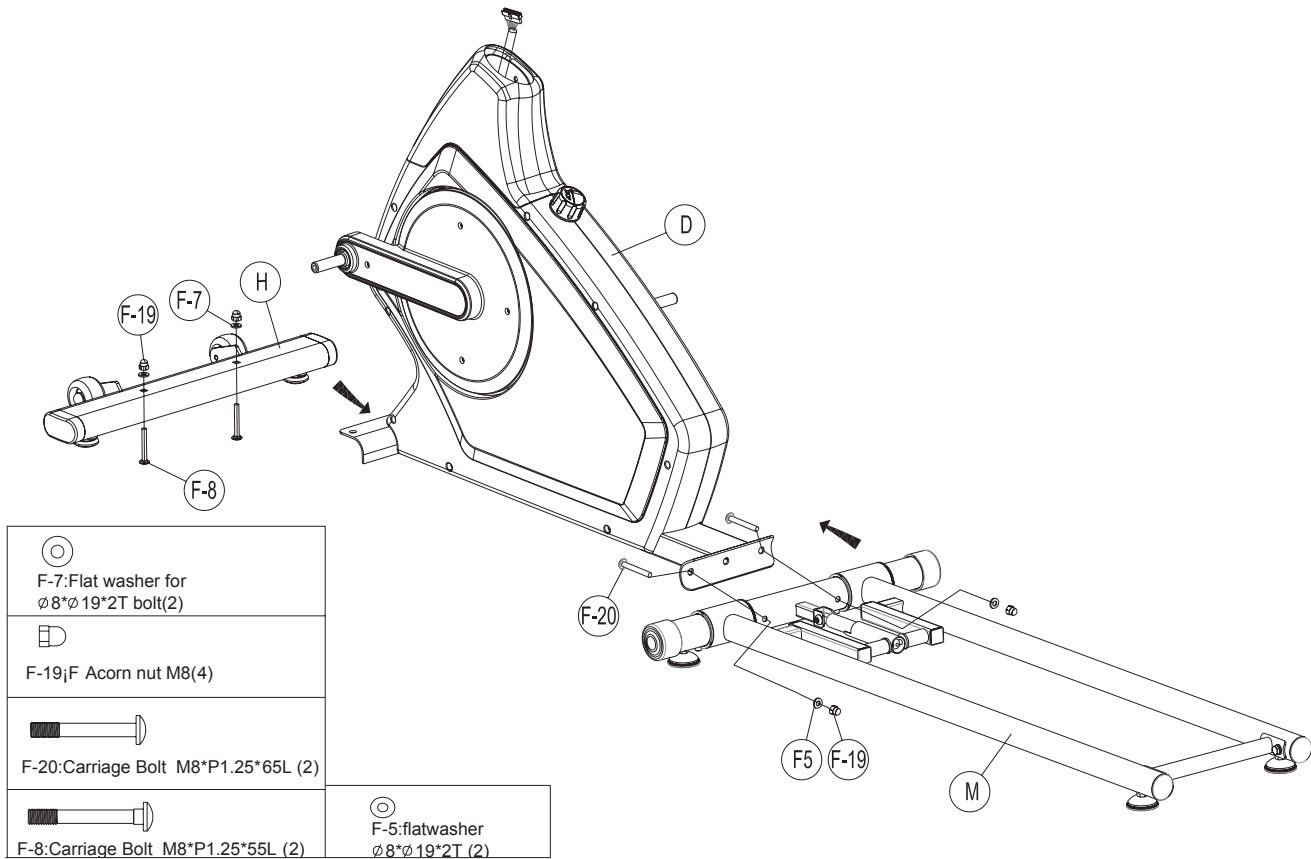

- Attach the front stabilizer (H) firmly to the main frame (D) using 2 flat washers (F-7), 2 flat head lock bolts (F-8) and 2 nuts (F-19);
- Attach the rear stabilizer (M) firmly to the main frame (D) using 2 flat washers (F-7), 2 flat head lock bolts (F-20) and 2 nuts (F-19).

STEP 2

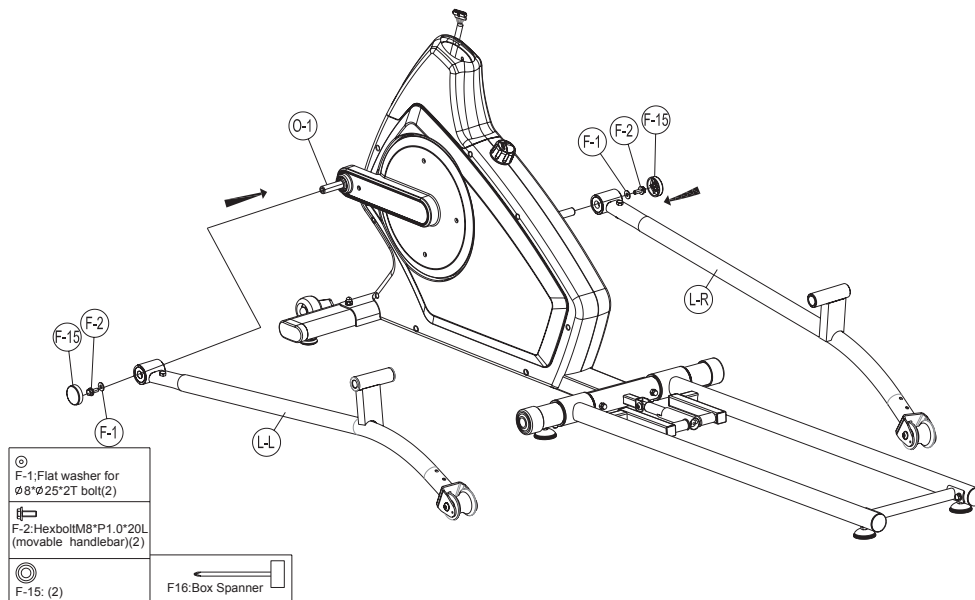

- Mount the left crank arm (L-L) to the left crank (O-1) using 1 flat washer (F-1), 1 screw (F-2) and 1 cap for screw (F-15);
- Mount the right crank arm (L-R) to right crank (O-1) using 1 flat washer (F-1), 1 screw (F-2) and 1 cap for screw (F-15).

STEP 3

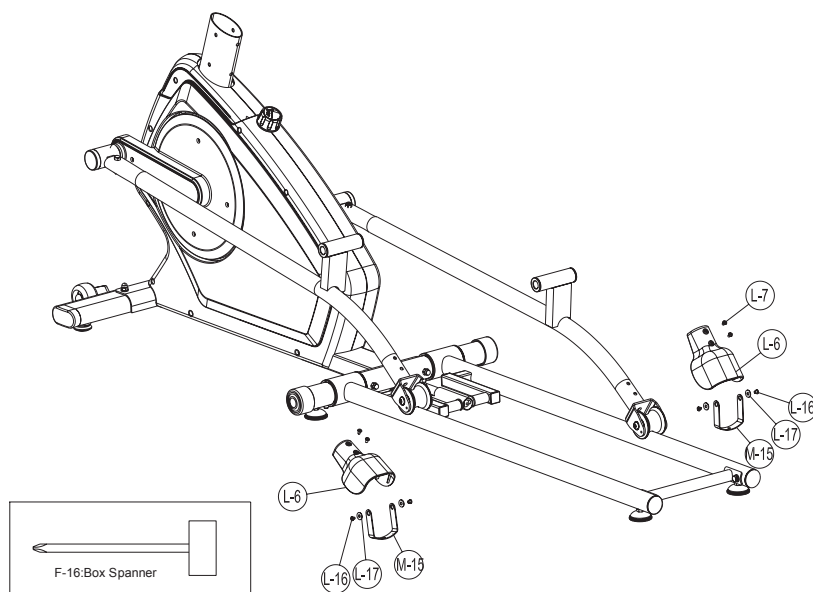





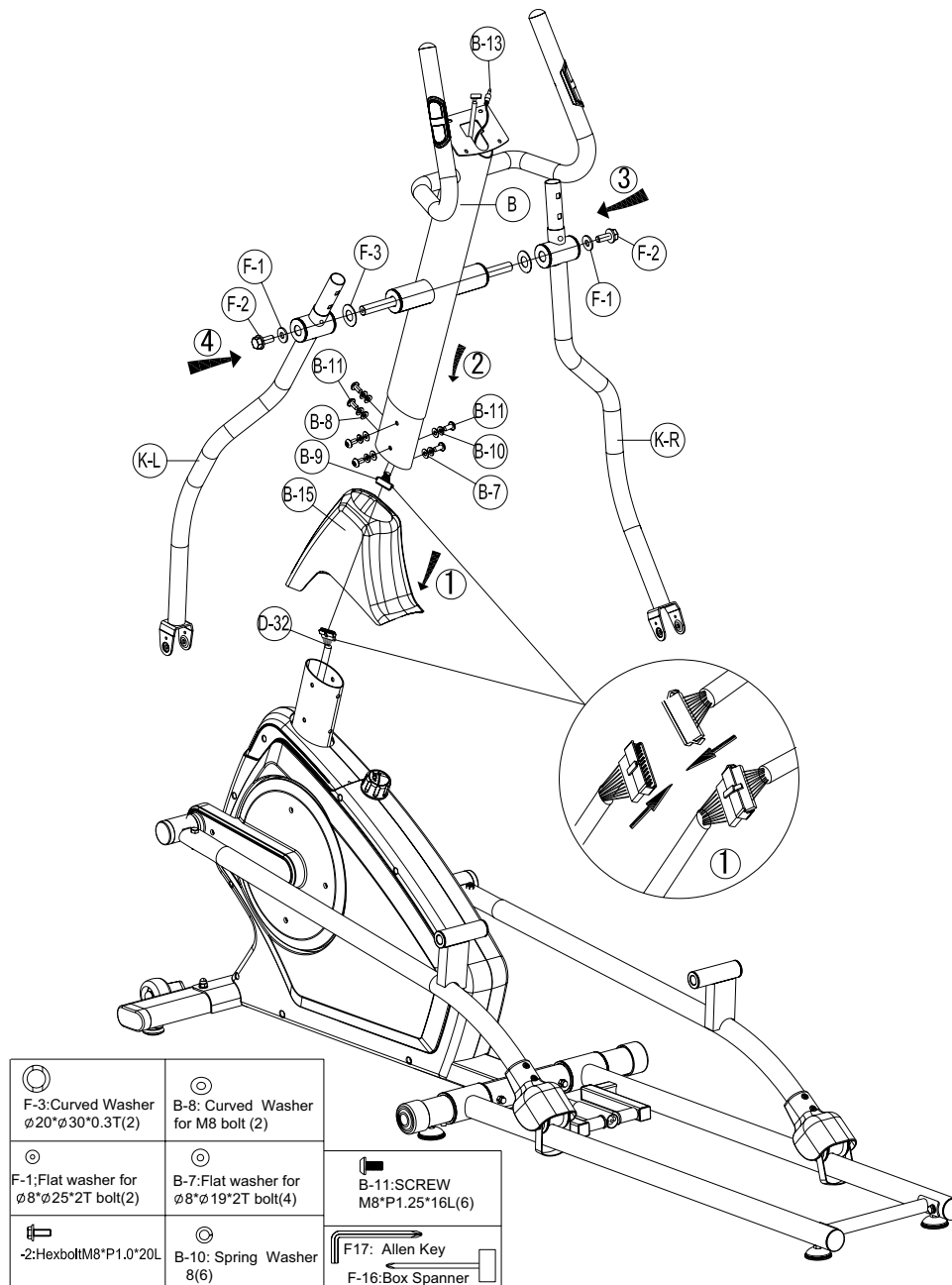



- Mount the covers (L-6) on sliders with screws (L-7) and fasten the lockers (M-15) with screws and washers (L-16 & L-17).

STEP 4



- Connect the cable wire (upper) (B-9) to the cable wire (lower) (D-32);
- Attach the handlebar post set (B) to the main frame with 4 flat washers (B-7), 2 half circle washers (B-8), 6 spring washers (B-10) and 6 screws (B-11);
- Mount the right-hand lower handlebar (K-R) on the steering shaft with 1 flat ring (F-1), 1 nylon screw (F-2) and 1 wave ring (F-3).

STEP 5

	F-4: lock nut for M8 bolt (2)
	F-9: FlatWasher $\varnothing 8^* \varnothing 16^* 1T(2)$
	F-10: $\varnothing 16^* 36.5L$ bolt(2)
	F-11: allen bolt M8*P1.25*50L(2)
	I-5: Flat washer for $\varnothing 8^* \varnothing 19^* 2T$ bolt(6)
	I-6: SCREW M8*P1.25*16L(6)
	I-4: (2)
	F-17: Allen Key
	F-16: Box Spanner

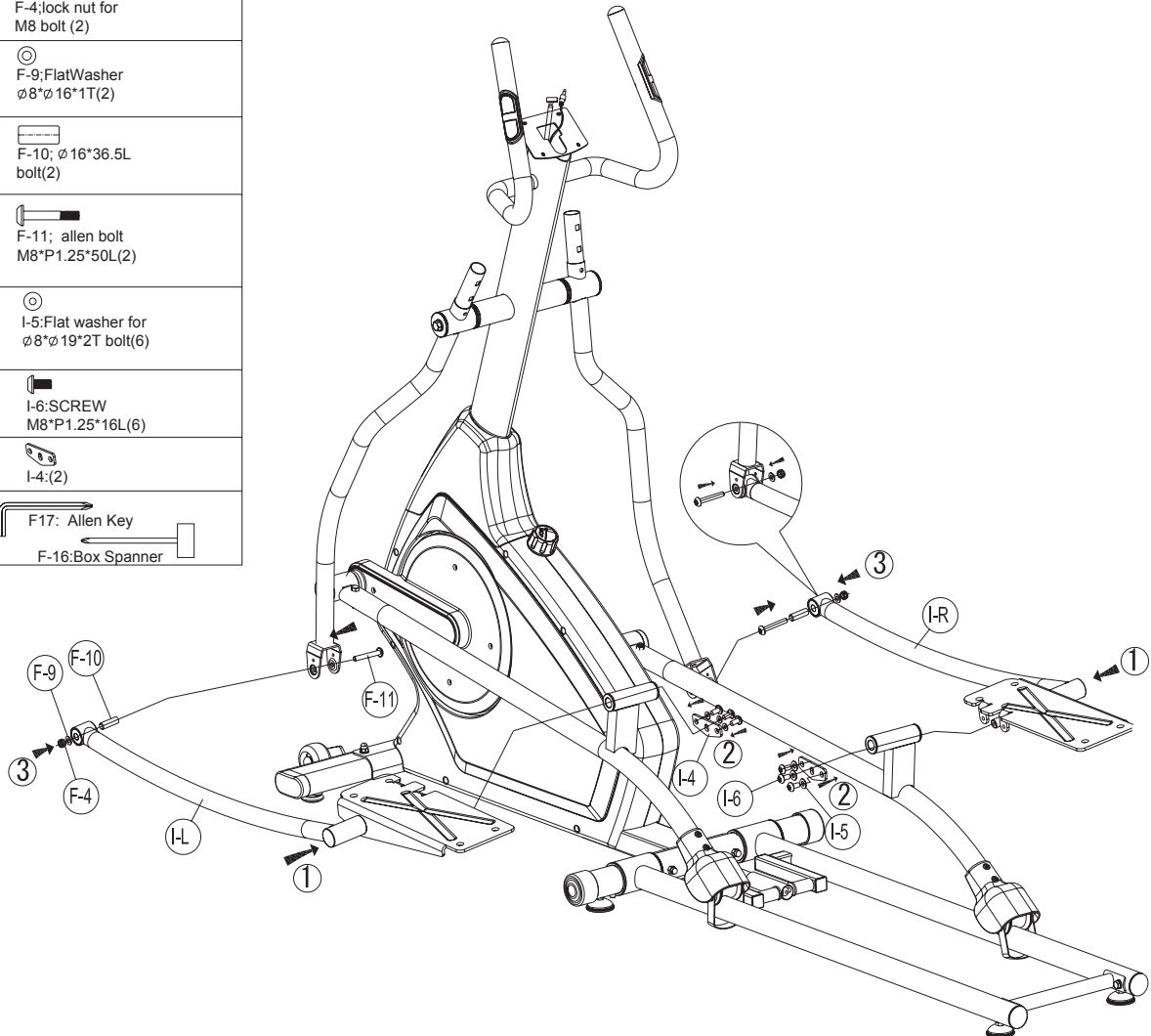

- Mount the right pedal arm (I-R) on the right bottom handle (K-R) using 1 nylon nut (F-4), 1 flat washer (F-9), 1 sleeve (F-10);
- Attach the left pedal arm (I-L) to the left crank arm (LL) and then secure it with 1 pedal connector (I-4), 3 flat washers (I-5) and 3 screws (I-6);
- Attach the right pedal arm (I-R) to the right crank arm (LR) and then secure it with 1 pedal connector (I-4), 3 flat washers (I-5) and 3 screws (I-6);
- Fit the left pedal arm (I-L) to the left lower handlebar (K-L) using 1 nylon nut (F-4), 1 flat washer (F-9) and 1 sleeve (F-10);
- Mount the right pedal arm (I-R) on the right bottom handle (K-R) using 1 nylon nut (F-4), 1 flat ring (F-9) and 1 sleeve (F-10).

STEP 6

F-13: SCREW M5*12L(8)
F-14: FlatWasher ø6*ø16*1T(8)
F17: Allen Key

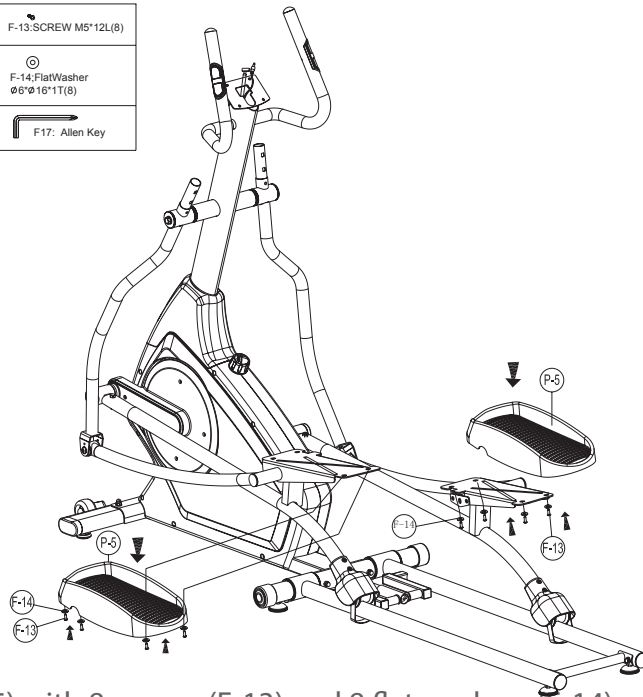

- Mount the pedals (P-5) with 8 screws (F-13) and 8 flat washers (F-14)

STEP 7

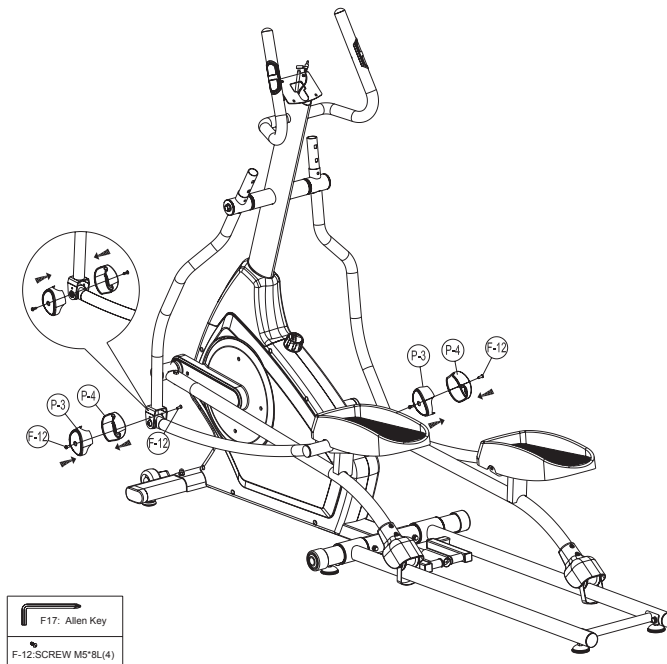

F17: Allen Key
F-12: SCREW M5*8L(4)

- Mount the left and right valve for pedal arms (P-3 and P-4) with 4 screws (F-12).

STEP 8

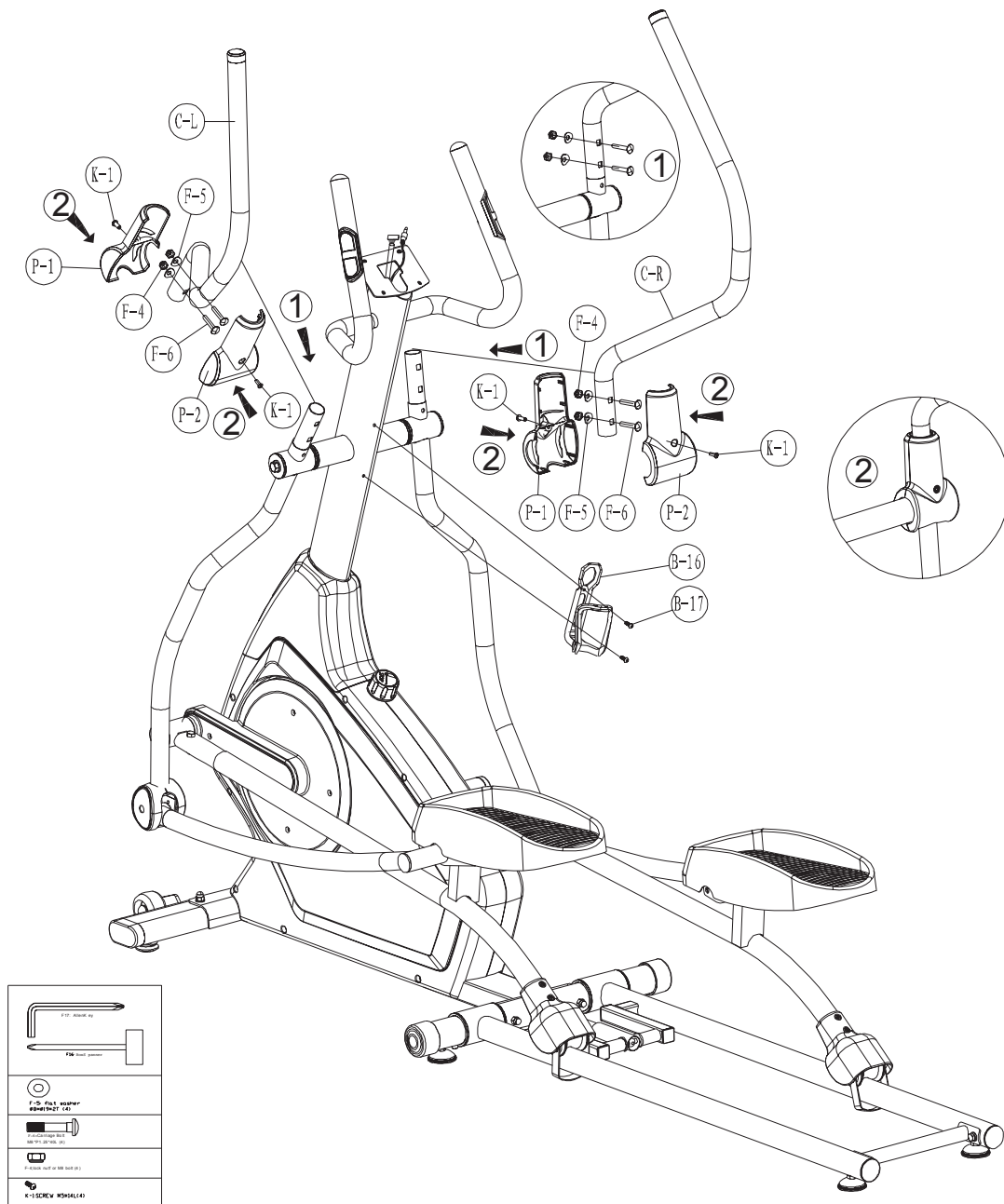

- Mount the left upper handlebar (C-L) on the lower left handlebar using 4 nylon nuts (F-4), 4 half circle washers (F-5), 4 carriage screws (F-6);
- Mount the right-hand top handlebar (C-R) on the lower right handlebar using 4 nylon nuts (F-4), 4 half circle washers (F-5), 4 carriage screws (F-6);
- Place the front panel for the upper handlebar (P-1) and the rear panel for the upper handlebar (P-2) on the handlebars on the left and right and secure them with 4 screws (K-1);
- Mount the water container (B-16) with screw (B-17).

STEP 9

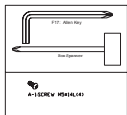
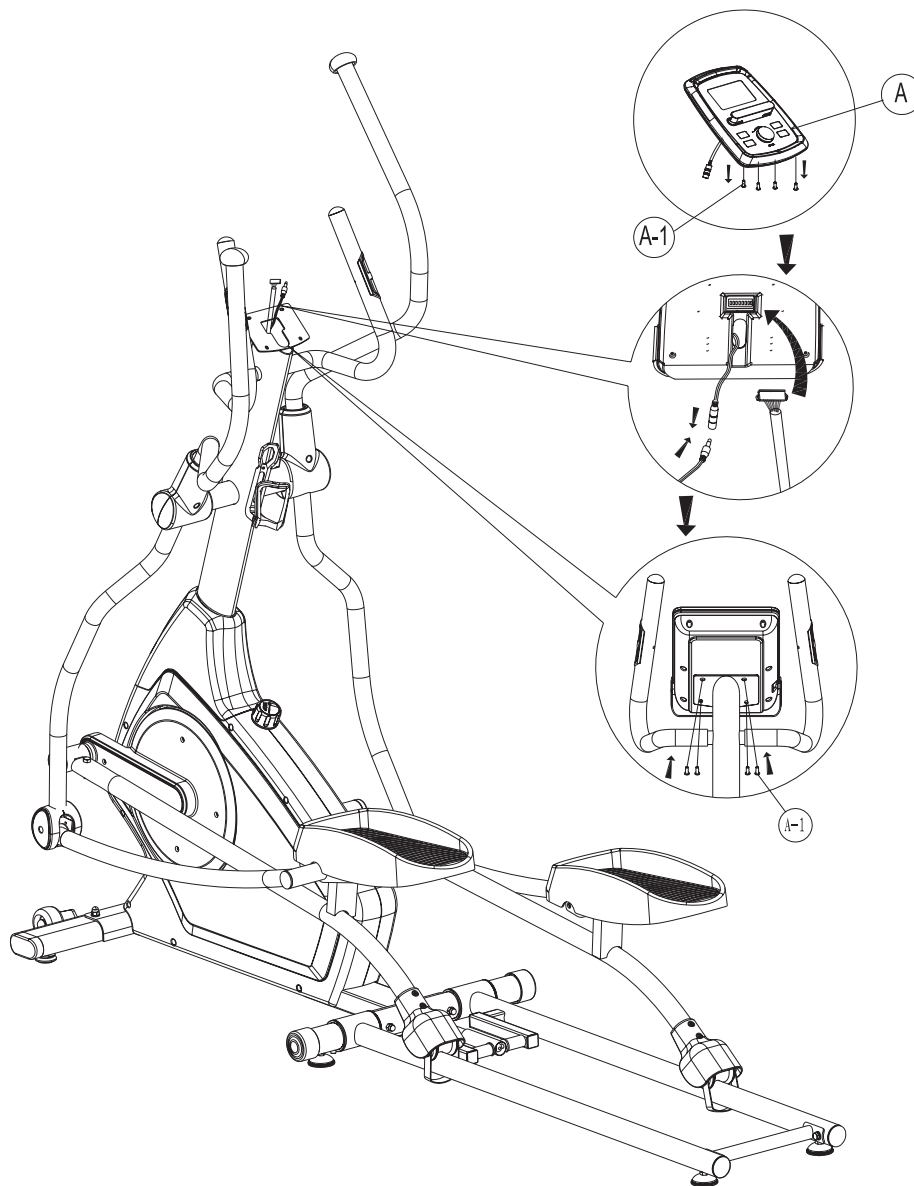

- Connect the cable wire (upper) (B-9) and the handpole cord (B-13) to the back of the computer (A) make sure cables don't damage;
- Install the computer (A) on the computer panel that is welded to the top of the steering rod. Attach the computer with 4 screws (A-1).

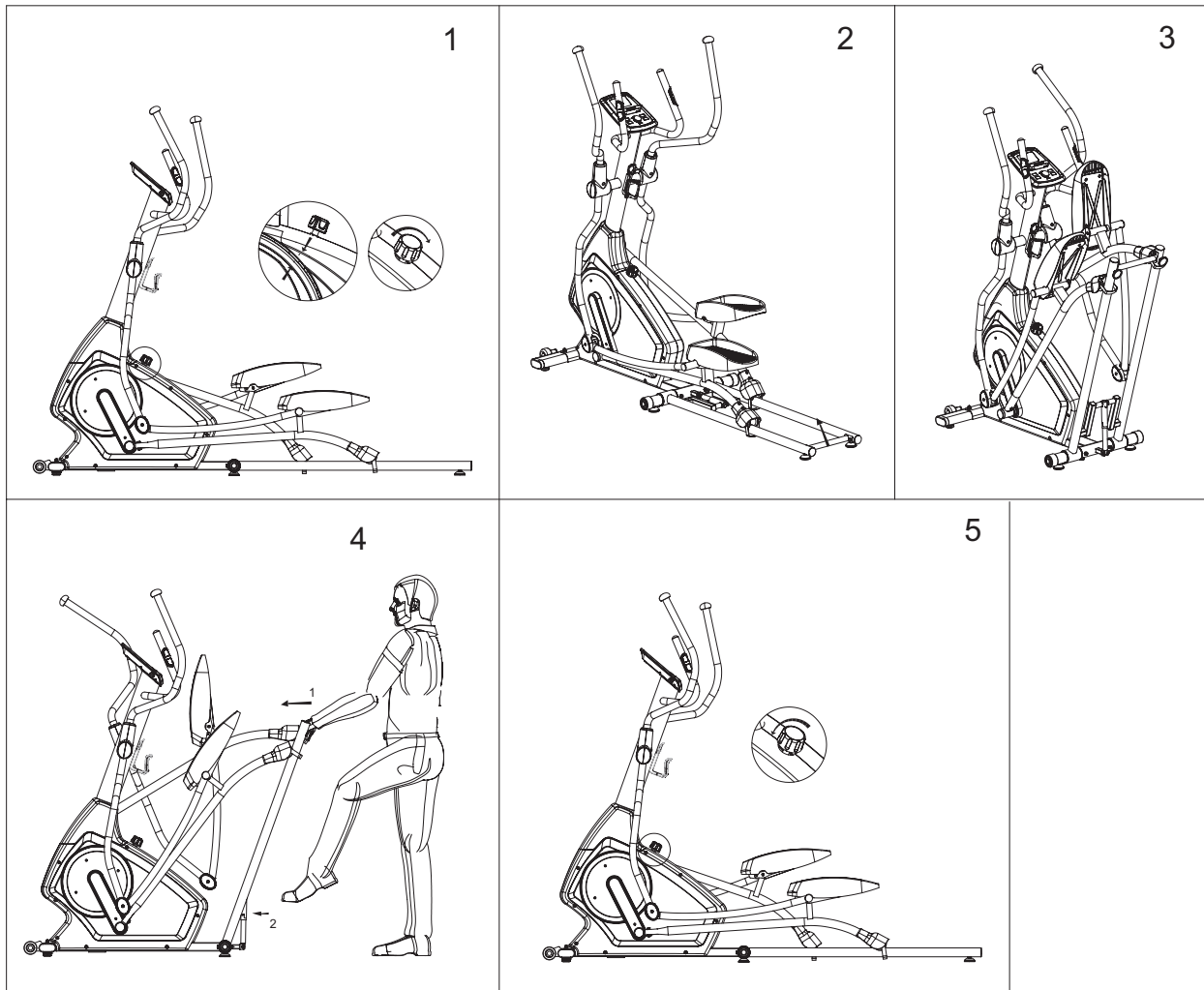

1. Find the knob in the front the chain cover and fix the knob with clockwise direction (make the two marks "arrow on the cranks" in one line). **Figure 1**
2. Lift up linkage tube of rail until you hear a "click". **Figure 2 & 3**
3.
 - a. Push forward the rail.
 - b. Kick the foldable cylinder which area is sticker with the following yellow label by feet
 - c. Continue to kicking and push gently back until the cylinder is fully change angel as following.

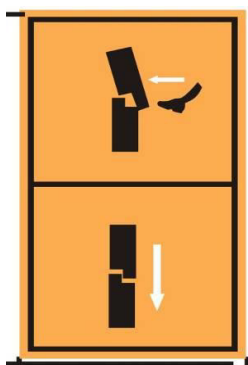

1. The upright is fixed with Allen screws, making sure that the bolts are tight at all times. If the bolts are not tightened tight enough, this can cause cracking.
2. All moving parts mounted on the base of the device should be greased with grease once every 6 months. This can be done with Vaseline (without acids) or with silicone oil.
3. After each use, the appliance should be cleaned with a slightly damp cloth and soft soap. If the perspiration is not removed in time, corrosion can occur.
4. Do not place the cross trainer in a room with high humidity. For example, a shed or a room where the washing machine is located.

PROBLEM SOLUTIONS

Squeaky crosstrainer: First lubricate all rotating parts with silicone spray. It can also be that a screw is tightened too tightly or too loosely, this creates friction and therefore a beep. If this is the case, try to find out exactly where the beep is coming from and then loosen or tighten this screw. The screws should be tightened in such a way that they can always be released by hand.

No resistance: First check whether you can hear the motor running. You will hear the motor spin very briefly when you increase or decrease the resistance. If you hear the engine running then all electronics are OK, but the V-belt probably ended. You can then open the housing and replace the V-belt. If you do not hear the motor running, it may be that the motor or display is defective. First check whether the cable that runs upwards in the pipe is connected properly.

Ticking sound: It is possible that the flywheel (in the housing) comes against a cable with every pedaling. This may be disturbing but will not cause permanent damage to your cross trainer. To solve this, open the housing and move the cable or you can fasten it with for example a tie-wrap.

Heart rate display does not work: This can have various causes. 1. The sensor cable running from the heart rate sensor to the display is not properly mounted or has come off during use. 2. It may be that the sensors have become damp, dirty or greasy, clean them regularly. 3. If you have a lot of calluses on your hands, it is more difficult for the sensors to measure, when this is the case a chest strap is recommended.

FUNCTION BUTTON



- | | |
|----------------|--|
| 1. Recovery | Test your heart rate recovery. |
| 2. Body fat | Test your fat percentage and BMI |
| 3. Reset | <ul style="list-style-type: none"> - Press and hold for 2 seconds, computer start again. - Return to main menu, restores the values or stop mode |
| 4. Start/ Stop | Start of Stop your workout. |
| 5. Encoder | <ul style="list-style-type: none"> - Increase / reduce the value. - Confirm / value selection. |

DISPLAY FUNCTIES BUTTON

TIME	Workout time during your exercise. Range 0:00 ~ 99:59
SPEED	Workout speed during your exercise. Reach 0.0 ~ 99.9
DISTANCE	Workout distance during your exercise. Reach 0.0 ~ 99.9
CALORIES	Burned calories during your exercise. Range 0 ~ 999
PULSE	BPM during your exercise. (heartbeat) Heart rate alarm when the heart rate goes over the target.
RPM	Rotations per minute Range 0 ~ 999
WATT	Workout power consumption The computer retains its set value (adjustable value range 0 ~ 350)
MANUAL	Manual workout.
PROGRAM	12 PROGRAM selections.
USER	The user determines his own resistance program
H.R.C.	Heart Rate Control (program based on heart rate)
RECOVERY	Heartbeat recovery status.
BODY FAT	Body fat measurement.
WATTS	Workout power consumption. Range 10 ~ 350.

OPERATION

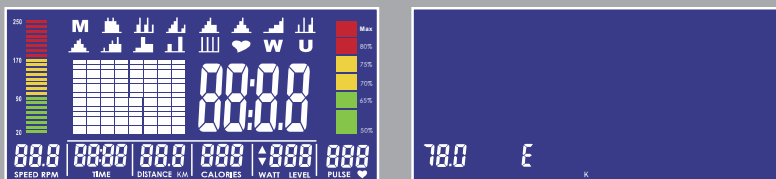

1. Insert the plug into the wall socket (or press and hold RESET button for 2 seconds), the display will light up and you will hear a beep.

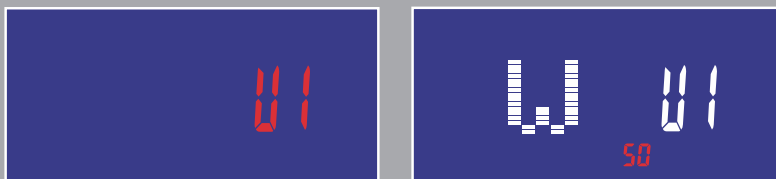

2. By turning the knob you select a user profile 1-4. By clicking on the round button you select a profile. You can then enter your gender by turning the button. Press the round button to confirm. This then also applies to your age, height and weight. Then go to the programs.

You can also start quickly by pressing the START button directly. You come directly into the manual program. Increase the resistance by turning the knob.

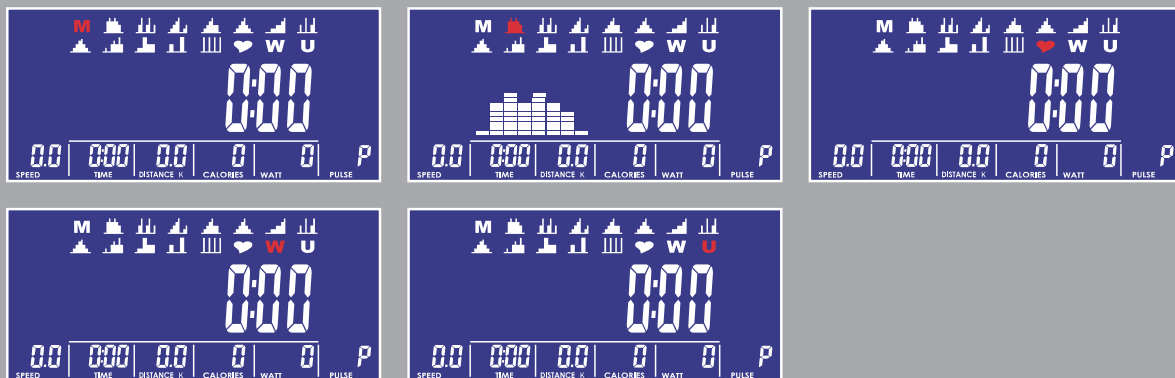

3. By turning the round button you select which program you want, you can see this on it flashing logo at the top of the screen.

The M stands for Manual. You can adjust the resistance yourself in the program. Press start to select a program. You can select different programs by turning the rotary knob. Press start to start the program. Do you want to adjust the program on time or on a desired calories number? Then first press the round button. You can check what is flashing increase / decrease by means of turning the knob. Press the button to confirm. Press start to start the program.

With the manual program you can set different values, with the pre-programmed programs only the time.



4-1

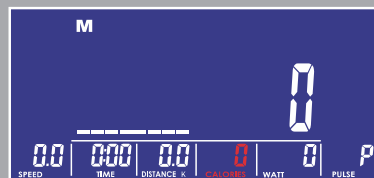
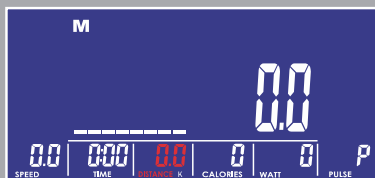

4-2

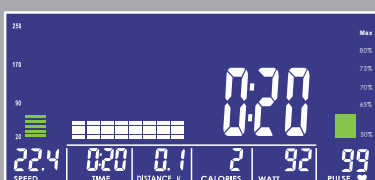

4-3

4. Manual mode

- (1) When you are in manual mode, you can increase and decrease the resistance with the knob.
- (2) By pressing "START" distance, time, calories and pulse can be increased and decreased. For example, you can select 10 minutes, the time will then expire. This allows you to set up a 10-minute workout.

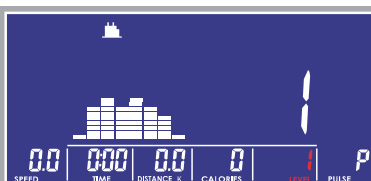
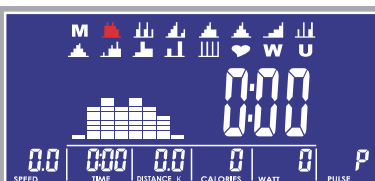

5. Program mode

- (1) Press and hold the RESET button until the unit beeps.
- (2) Select a USER 1-4 by pressing the round button. Hold down until the screen appears as shown in the drawing above. The MANUAL M flashes now. By turning the round button you can now select a program.
- (3) Press the round button to confirm the program. You can press the button at the touch of a button adjust the degree of difficulty by turning it afterwards. The time flashes after pressing the button. You can now set the time by turning the knob. Select the desired time and press "START" to start the program.

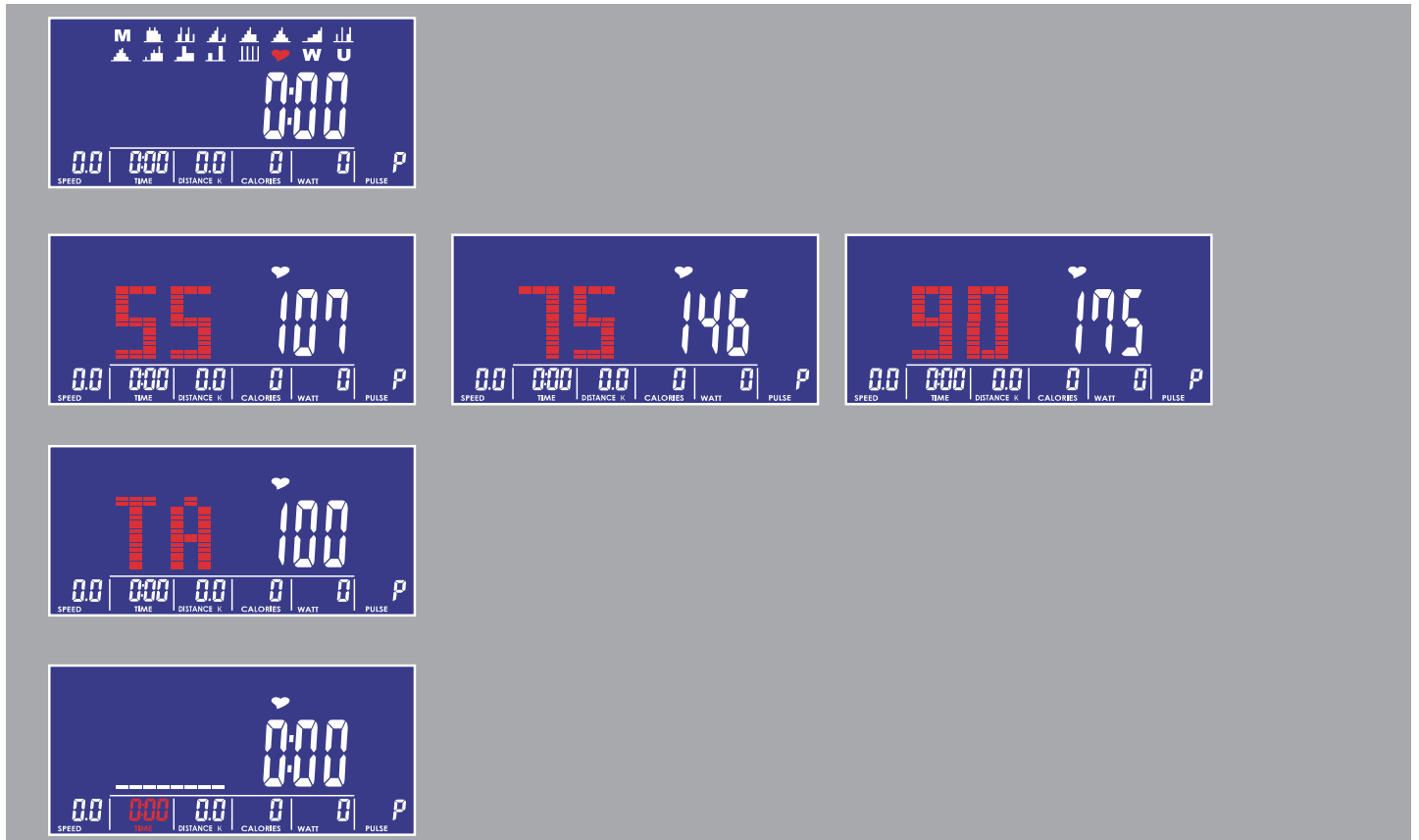

6. H.R.C heart rate mode

- (1) The user can select 55%, 75%, 90% and target values by turning the button. TARGET can be set to not exceed a certain value. If these are set at 80 heartbeats per minute and you come above, the device starts beeping. Note: the heart rate measurement should not be used for medical purposes and is only an approximation.
- (2) Start the device. Press the round button to set USER 1-4, then turn the HART symbol in the start screen. Press the round button. Turn the knob to select. Press the button to choose. Time can then be set by turning and pressing on and on the button. Then press START to start.

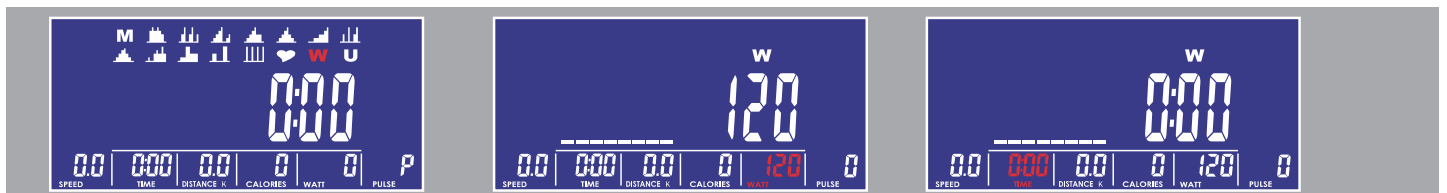

7. WATT mode

- (1) By turning and then pressing the button you can adjust the WATT values. By once again, you can also set the time.
- (2) Press START to start training. WATT can be adjusted during training. You can enter a maximum value. If you go over this, the device starts to beep.

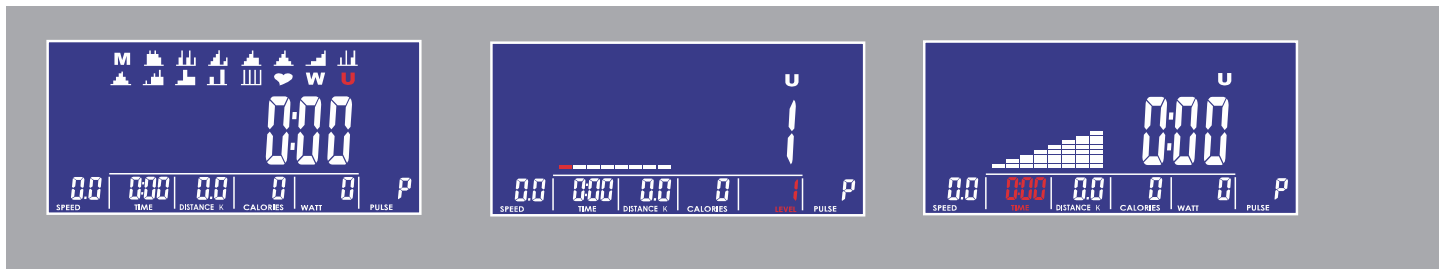

8. User program mode

You can create a program yourself in this mode.

- (1) Press and turn the round button to select the U.
- (2) Press and turn the knob to change the resistance per beam.
- (3) Press START to begin. Press START again to adjust the time by turning the knob. Press START again to resume. The resistance will change automatically as you have set it.

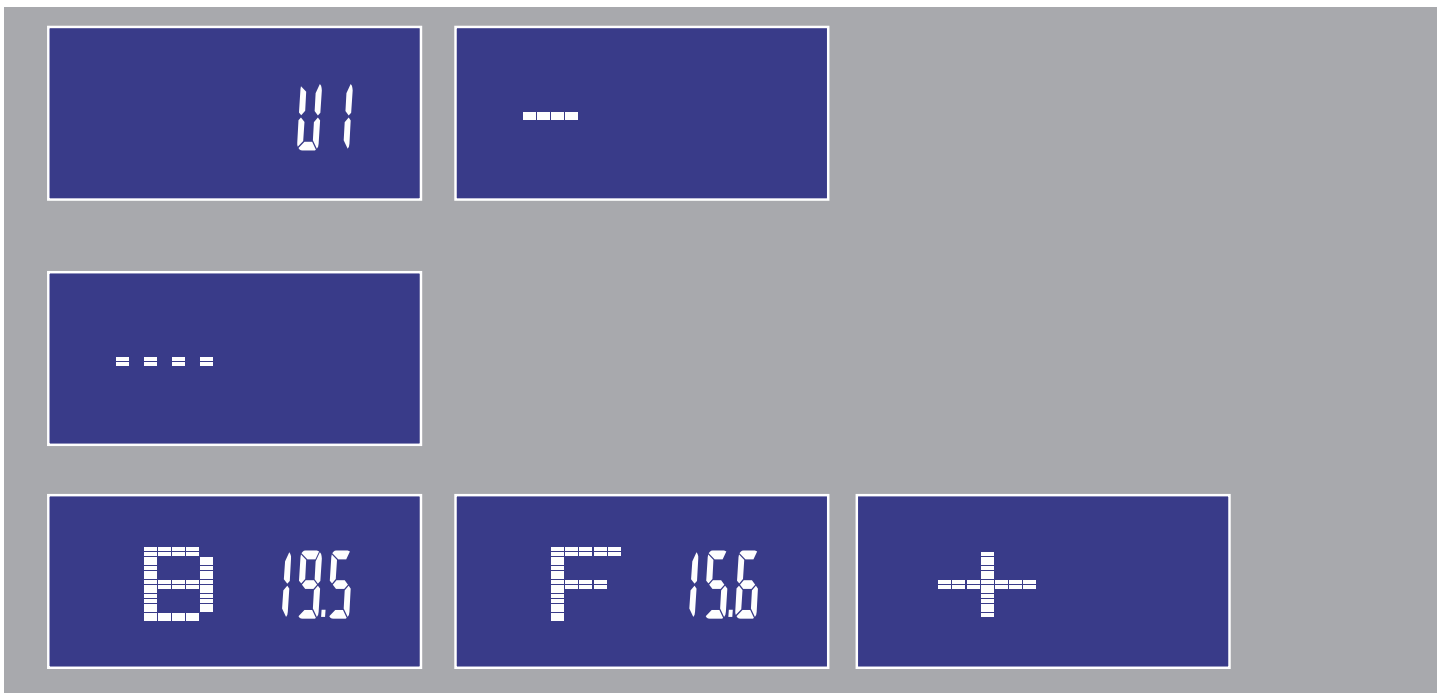

9. Body fat mode

- (1) Press the Body Fat button. You can then choose U1-U4 to select your user program which you can change when starting or resetting the device.
- (2) After selecting, you can place your hands on the heart rate sensors on the steering wheel.
- (3) After a few seconds, an approximation of your BMI (B) and your body fat percentage (F) will appear.

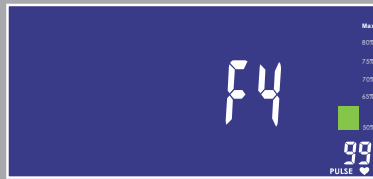

1.0	OUTSTANDING
1.0 < F < 2.0	EXCELLENT
2.0 < F < 2.9	GOOD
3.0 < F < 3.9	FAIR
4.0 < F < 5.9	BELOW AVERAGE
6.0	POOR

10. Recovery mode

This mode measures how quickly you recover from a workout.

- (1) Make sure the device measures your heart rate during training. When you do a heart rate measurement during your workout press "RECOVERY".
- (2) Time and heart rate are displayed. The time counts down from 60 seconds and the current heart rate is displayed. You do not have to cycle.
- (3) The faster your heart rate falls, the better your condition.

Pay attention. This is an estimate. The results should not be used for medical purposes.

Training using an app.

First you need to download one of the apps. Depending on the operating system of the tablet or smartphone, you must go to Google Play Store or Apple App Store to download the app. You can also scan the QR code to download the app directly.

After the app has been successfully downloaded, you must complete the following steps to connect the crosstrainer and phone/tablet.

For Apple smartphones or tablets

1. Go to option settings of your smartphone or tablet and turn on the bluetooth function.
 2. Next, bluetooth devices are searched for. The name of the app appears in the list.
 3. Select it and the two devices will search for a connection.
 4. Then type the code 0000 so that the two devices are connected to each other.
 5. When the two devices are connected, the computer automatically turns off and you can use the crosstrainer through your phone.
- (If you close the app and disconnect it, the computer will restart.)

For Android smartphones or tablets

1. Go to option settings of your smartphone or tablet and turn on the bluetooth function.
 2. Start the app now.
 3. Press the bluetooth icon with rotating arrows for the list of bluetooth devices.
 4. Select the name of the app in this list to connect.
 5. When the two devices are connected, the computer automatically turns off and you can use the crosstrainer through your phone.
- (If you close the app and disconnect it, the computer will restart.)

ANDROID

IOS



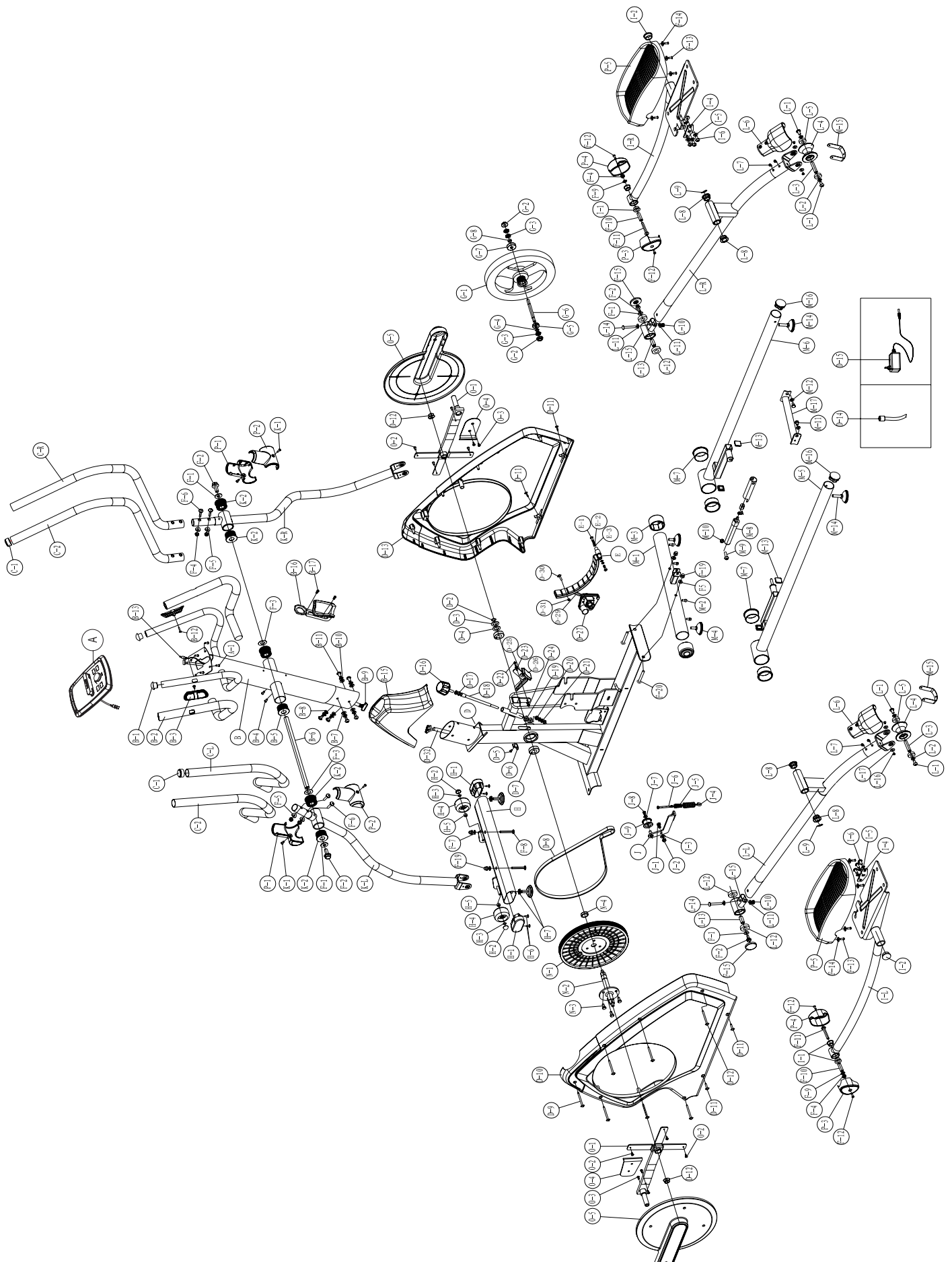

No.	Description	Q'ty
A	Computer	1
A-1	Screw	4
B	Handlebar post set	1 (set)
B-1	End cap for front handlebar	2
B-2	Foam grip for front handlebar	2
B-3	Hand pulse	2
B-4	Screw	2
B-5	Sleeve	2
B-6	Axle for handlebar	1
B-7	Flat washer	4
B-8	Semicircle washer	2
B-9	Cable wire (upper)	1
B-10	Spring washer	6
B-11	Screw	6
B-12	Screw	2
B-13	Hand pulse wire	2
B-14	Screw	2
B-15	Cover for handlebar post	1
B-16	Water bottle holder	1
B-17	Screw for fixing holder	2
C-L	Left upper handlebar	1 (set)
C-R	Right upper handlebar	1 (set)

No.	Description	Q'ty
C-1	End cap for upper handlebar	2
C-2	Foam grip for upper handlebar	2
D	Main frame	1 (set)
D-2	C-type ring	1
D-3	Flat washer	1
D-4	Wave Washer	1
D-5	Screw for sensor box	1
D-6	Sensor box	1
D-7	Bearing	2
D-8	Belt	1
D-9	Screw	7
D-10	Chain cover (L)	1
D-11	Screw	4
D-12	Nut	2
D-13	Chain cover (R)	1
D-14	DC Wire 1	1
D-15	Adapter	1
D-16	Brake knob	1
D-17	Nut	2
D-18	Axle for brake	1
D-19	Nut	2
D-20	Nylon nut	2
D-21	Flat washer	2

No.	Description	Q'ty
D-22	Screw	1
D-23	Flat washer	2
D-24	Nylon nut	1
D-25	Brake plate	1
D-26	Felt	1
D-27	Motor bracket	1 (set)
D-29	Axle for gear box	1
D-30	Screw	1
D-31	Nut	1
D-32	Cable wire (lower)	1
E	Eddy magnet assembly	1 (set)
E-1	Screw	2
E-2	Flat washer	2
E-3	Spring washer	2
F	Screw set	1 (set)
F-1	Flat washer	4
F-2	Nylon screw	4
F-3	Wave washer	2
F-4	Nylon nut	6
F-5	Semicircle washer	4
F-6	Carriage screw	4
F-7	Flat washer	4
F-8	Carriage screw	2

No.	Description	Q'ty
F-9	Flat washer	2
F-10	Sleeve	2
F-11	Allen bolt	2
F-12	Screw	4
F-13	Screw	8
F-14	Flat washer	8
F-15	Cover for screw	2
F-16	Box spanner	1
F-17	Allen key	1
F-19	Nut	4
F-20	Carriage screw	2
G	Flywheel set 1	1 (set)
G-1	Flywheel 1	1
G-2	Nut	2
G-3	Nut	3
G-4	Flat washer	1
G-5	Bearing	1
G-6	Axle for flywheel	1
G-7	Bearing	1 (set)
G-8	Bushing	1
H	Front stabilizer set	1 (set)
H-1	Foot cap for front stabilizer	2
H-2	Nut	2

No.	Description	Q'ty
H-3	C-type ring	2
H-4	Transportation wheel	2
H-5	Sleeve	2
H-6	Screw	4
H-7	Adjustable foot cap	2
I-L	Left pedal arm	1 (set)
I-R	Right pedal arm	1 (set)
I-1	Sleeve	4
I-2	End cap	2
I-4	Pedal connector	2
I-5	Flat washer	6
I-6	Screw	6
J	Idler	1 (set)
J-1	Hex. bolt	1
J-2	Nylon nut	1
J-3	Flat washer	1
J-4	Spring	1
J-5	Spring bracket	1
J-6	Hex. bolt	1
J-7	Flat washer	1
J-8	Hex. bolt	1
J-9	Idler wheel	1
K-L	Left lower handlebar	1 (set)

No.	Description	Q'ty
K-R	Right lower handlebar	1 (set)
K-1	Screw	4
K-2	Sleeve	4
L-L	Left crank arm	1
L-R	Right crank arm	1
L-1	Screw	4
L-2	Flat washer	4
L-3	Fixed stick for wheel	2
L-4	Wheel	2
L-5	Bearing	4
L-6	Cover for wheel	2
L-7	Screw	4
L-8	Bushing	4
L-9	Wave washer	2
L-10	Nylon nut	2
L-11	Flat washer	4
L-12	Bearing	4
L-13	Bushing	2
L-14	Bolt	2
L-15	Crank arm connect base	2
L-16	Screw	4
L-17	Flat washer	4
M	Rear stabilizer	1 (set)

No.	Description	Q'ty
M-1	Rear stabilizer	2
M-2	Screw	4
M-3	Rear stabilizer end cap	4
M-4	Stabilizer adjusting cap	2
M-5	Slide rail (left)	1
M-6	Slide rail (right)	1
M-7	Sleeve	4
M-8	Cylinder	1
M-9	Screw	1
M-10	Nylon nut	1
M-11	Hex. bolt	2
M-12	Semicircle washer	2
M-13	Square cap	4
M-14	Slider adjusting cap	2
M-15	U-shape locker	2
M-16	Slider end cap	2
M-17	Connection	1
N	Axle set	1 (set)
N-1	Pulley	1
N-2	Axle	1
N-3	Hex. bolt	3
N-4	Bushing	1
O	Disc cover and crank set	2 (set)

No.	Description	Q'ty
O-1	Crank (L+R)	2
O-2	Screw	10
O-3	Screw	2
O-4	Cover for disc cover	2
O-5	Disc cover	2
P-1	Front cover for upper handlebar	2
P-2	Rear cover for upper handlebar	2
P-3	Left cover for pedal arm	2
P-4	Right cover for pedal arm	2
P-5	Pedal	2

virtu-fit

For questions or missing parts please contact your dealer.