

virtu~~fit~~fit

HTR 2.0 Ergometer Hometrainer

Manual

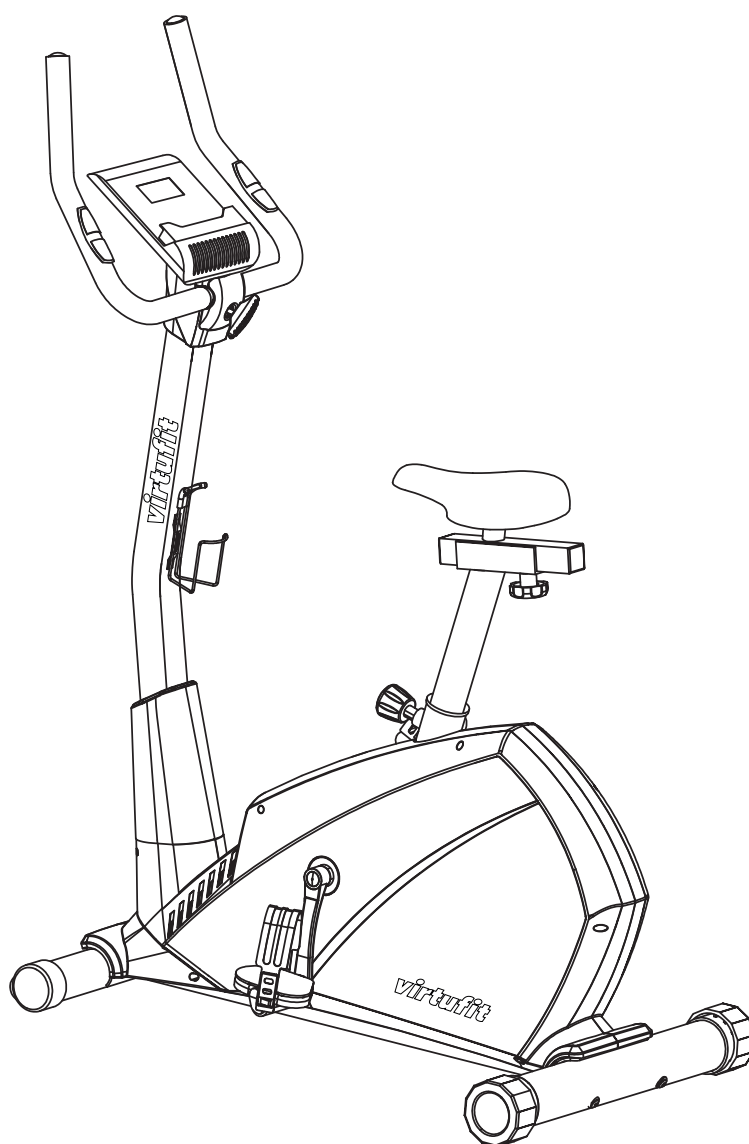

For questions or missing parts please contact Fitness Benelux:



Twekkelerweg 263
7553 LZ Hengelo
The Netherlands

T +31 (0)74-7600219
E service@fitnessbenelux.nl
W www.fitnessbenelux.nl

SAFETY PRECAUTIONS..... 3

EXPLODED DRAWING..... 4

PARTS LIST..... 5

ASSEMBLY INSTRUCTIONS..... 6

USER INSTRUCTIONS..... 12

DISPLAY INSTRUCTIONS..... 13

TRAINING INSTRUCTIONS..... 16

Thank you for purchasing this bike! For your safety and benefit, read this manual carefully before using the machine. Prior to assembly, remove components from the box and verify that all the listed parts were supplied. Assembly instructions are described in the following steps and illustrations.

- Check all the screws, nuts and other connections before using the machine for the first time and ensure that the trainer is in the safe condition.
- Set up the machine in a dry level place and leave it away from moisture and water.
- Place a suitable base (e.g. rubber mat, wooden board etc.) beneath the machine in the area of assembly to avoid dirt and damages.
- Before beginning training, remove all objects within a radius of 2 meters from the machine.
- DO NOT use aggressive cleaning articles to clean the machine, Only use the supplied tools or suitable tools of your own to assemble the machine or repair any parts of machine. Remove drops of sweat from the machine immediately after finishing training.
- Your health can be affected by incorrect or excessive training. Consult a doctor before beginning a training program. He can define the maximum setting (Pulse, Watts, Duration of training etc) to which you may train yourself and can get precise information during training. This machine is not suitable for therapeutic purpose.
- Only do training on the machine when it is in correct working way. Use only original spare parts for any necessary repairs.
- This machine can be used for only one person's training at a time.
- Wear training clothes and shoes which are suitable for fitness training with the machine. Your training shoes should be appropriate for the trainer.
- If you have a feeling of dizziness, sickness or other abnormal symptoms, please stop training and consult a doctor.
- People such as children and handicapped persons should only use the machine in the presence of another person who can give aid and advice.
- The power of the machine increases with increasing the speed, and the reverse. The machine is equipped with adjustable knob which can adjust the resistance. Reduce the resistance by turning the adjusting knob for the resistance setting towards stage 1. Increase the resistance by turning the adjusting knob for the resistance setting towards stage 8.

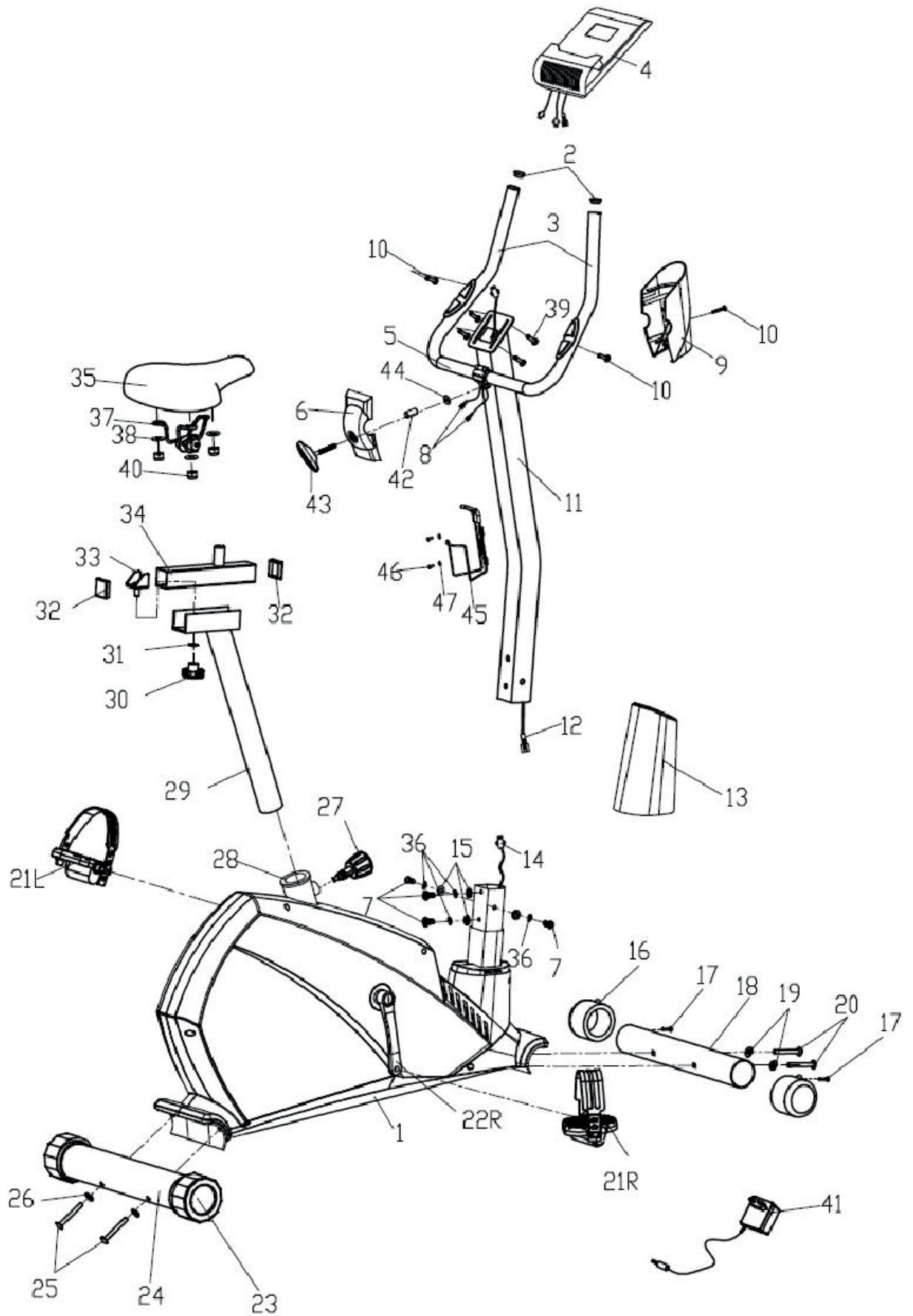

Most of the listed assembly hardware has been packaged separately, but some hardware items have been preinstalled in the identified assembly parts. In these instances, simply remove and reinstall the hardware as assembly is required.

Please reference the individual assembly steps and make note of all preinstalled

Nr.	Description	Quantity
1	Main Frame	1
2	Round End Cap	2
3	Hand grip foam	2
4	Computer	1
5	Handlebar	1
6	Front Handlebar Cover	1
7	Allen Bolt (M8X15)	8
8	Pulse Sensor Wire	2
9	Rear Handlebar Cover	1
10	Cross Tapping Screw (ST4.2X18)	3
11	Handlebar Post	1
12	Extension Sensor Wire	1
13	Protective Guard	1
14	Lower Sensor Wire	1
15	Flat Washer d8	4
16	Front End Cap	2
17	Cross Tapping Screw ST3.5X10	2
18	Front Stabilizer	1
19	Arc Washer d8XΦ19X1.5XR30	2
20	Allen Bolt M8XL72	2
21 L/R	Pedal (L/R)	1 pr
22 L/R	Crank(L/R)	1 pr

23	Rear End Cap	2
24	Rear Stabilizer	1
25	Allen Bolt M8XL90	2
26	Arc Washer d8X2 XΦ25 XR39	2
27	Pop-pin Knob M16X1.5X32	1
28	Saddle Post Bushing	1
29	Saddle Post	1
30	Knob Nut M10	1
31	Flat Washer d10	1
32	Square End Cap	2
33	U-shaped Slider	1
34	Horizontal Saddle Post	1
35	Saddle	1
36	Spring Washer (D8)	8
37	Saddle bracket	1
38	Flat Washer	3
39	Cross Screw M5X10	4
40	Nylon nut	3
41	Adaptor	1
42	Spacer	1
43	T-Handle knob	1
44	Flat washer	1
45	Bottle holder	1
46	Cross Tapping Screw	2
47	Flat washer	2

PREPARATION: Before assembling, make sure that you will have enough space around the item; use the present tooling for assembling; before assembling please check whether all needed parts are available. It is strongly recommended this machine to be assembled by two or more people to avoid possible injury.

STEP 1

1. Attach the front stabilizer (18) to the main frame (1) with the allen bolts (20) and arc washers (19)
2. Fix the rear stabilizer (24) to the main frame (1) with the allen bolts (25) and arc washers (26) as shown.

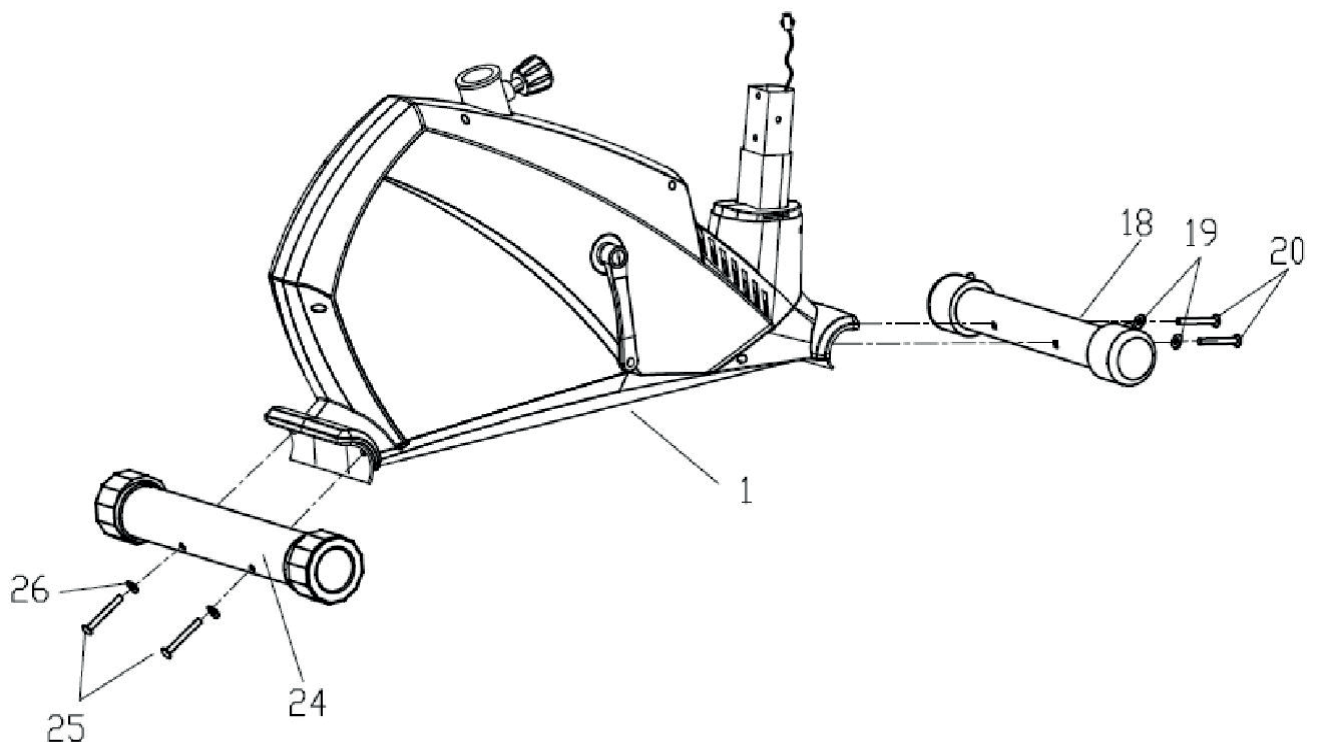

STEP 2

1. Slip the protective guard (13) onto the handlebar post (11);
2. Connect the lower sensor wire (14) to the extension sensor wire (12), and then fix the handlebar post (11) on the main frame (1), using the allen bolts (7), spring washers (36), and flat washers (15) as shown. Slip down protective guard (13) and fit in the place.

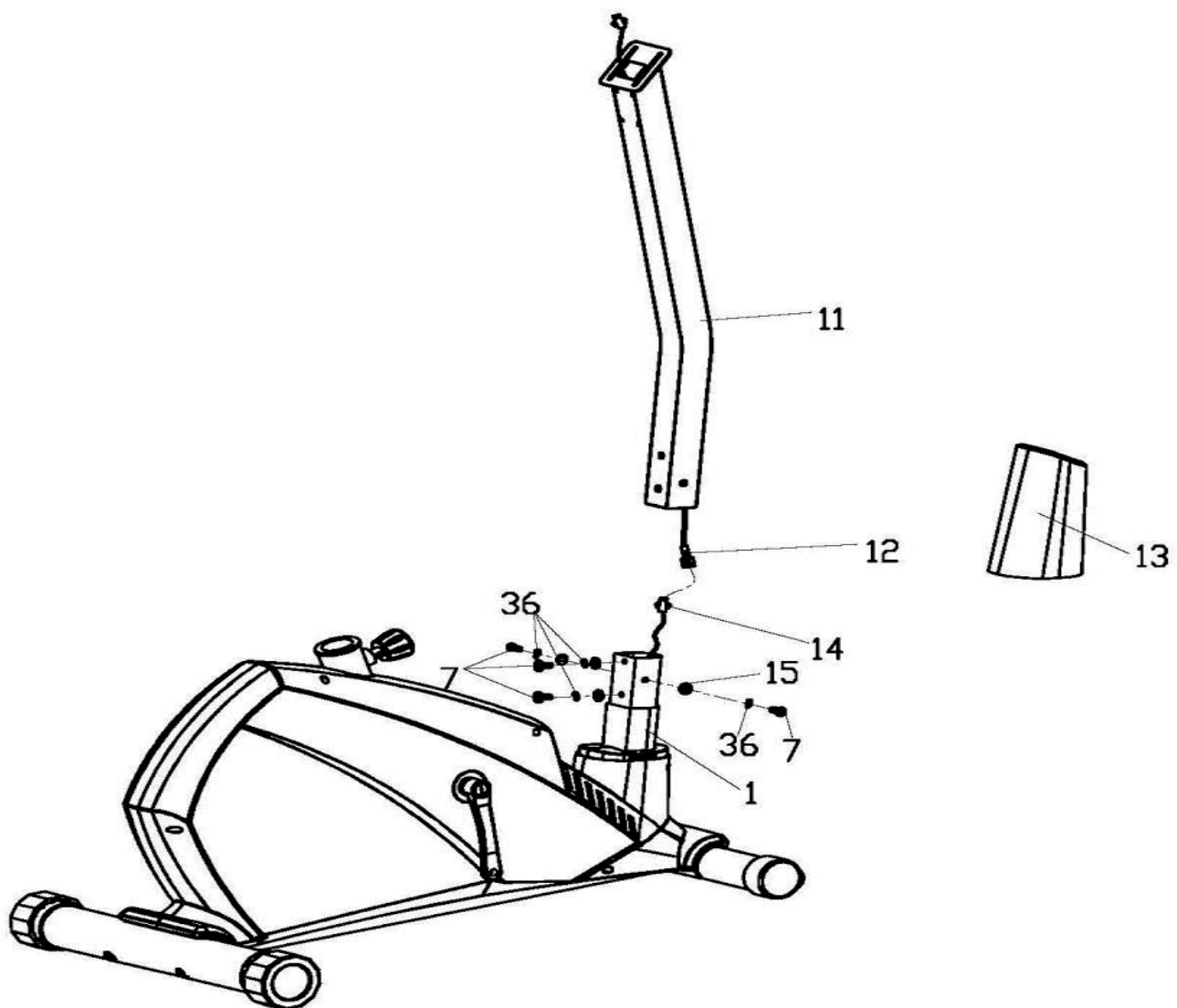

STEP 3

Attach the pedals (21L/R) to the cranks (22L/R) respectively, viewed from the rider's exercising position. Always make sure the pedals are securely tightened before any exercise.

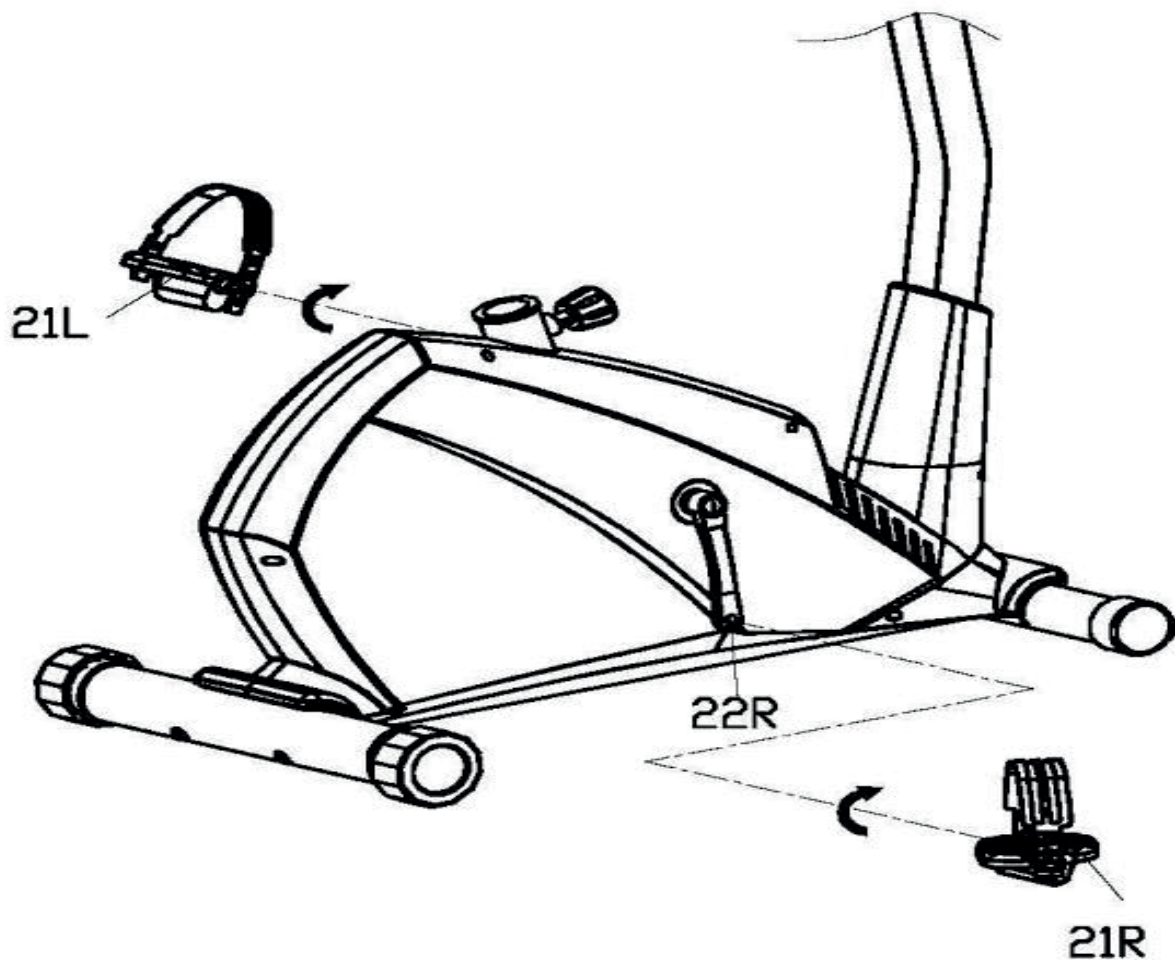

Note: both pedals are labeled L for left and R for right. To tighten turn the Left pedal counterclockwise and the right pedal clockwise.

STEP 4

1. Insert the saddle post (29) into the main frame (1), secured with the knob (27) at a proper height as shown.
2. And then fit the horizontal saddle post (34) to the saddle post (29), secured with the flat washer (31) and knob nut (30) as shown.
3. Install the saddle bracket (37) to the saddle (35) with flat washer (38) and nylon nut (40), Then attach the saddle (35) to the horizontal saddle post (34), secured the screw and nut under the saddle with wrench.

Note: make sure the saddle (35) has been tightly attached to the horizontal saddle post (34) before exercising.

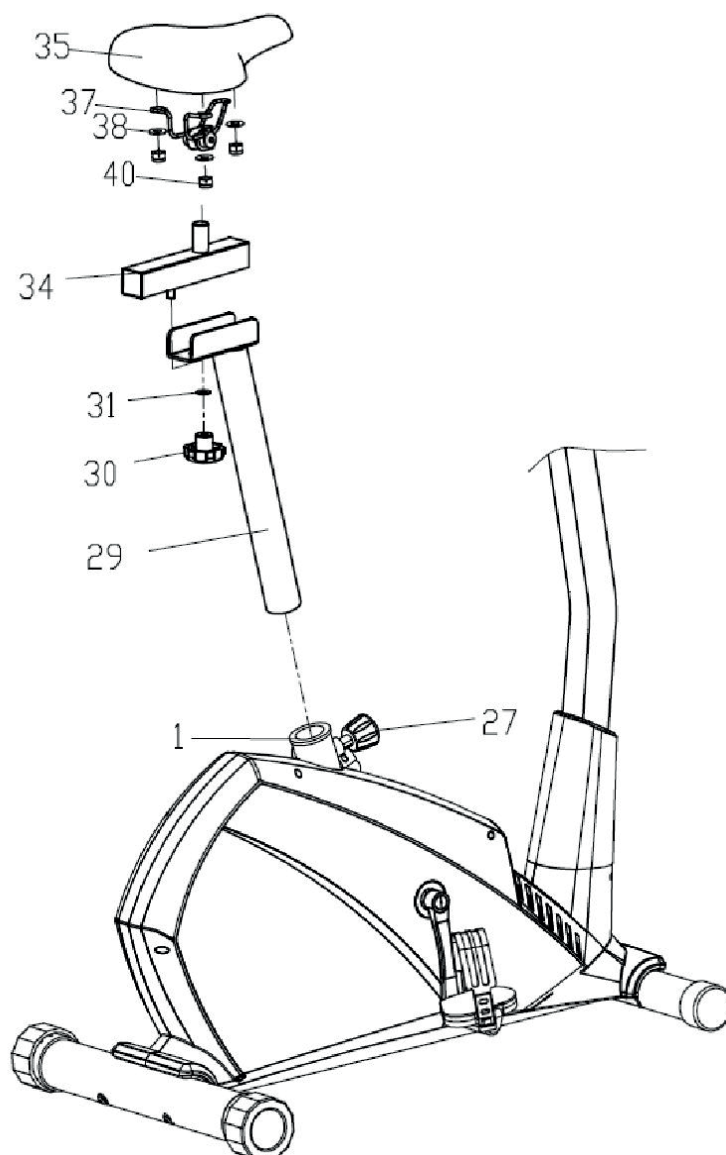

STEP 5

Feed the pulse sensor wires (8) through the computer bracket on the top of handlebar post (11). Attach the handlebar (5) to the handlebar post (11), then insert the t-handle knob (43) into the front handlebar (6) spacer (42) and flat washer (44) to lock the handlebar tightly.

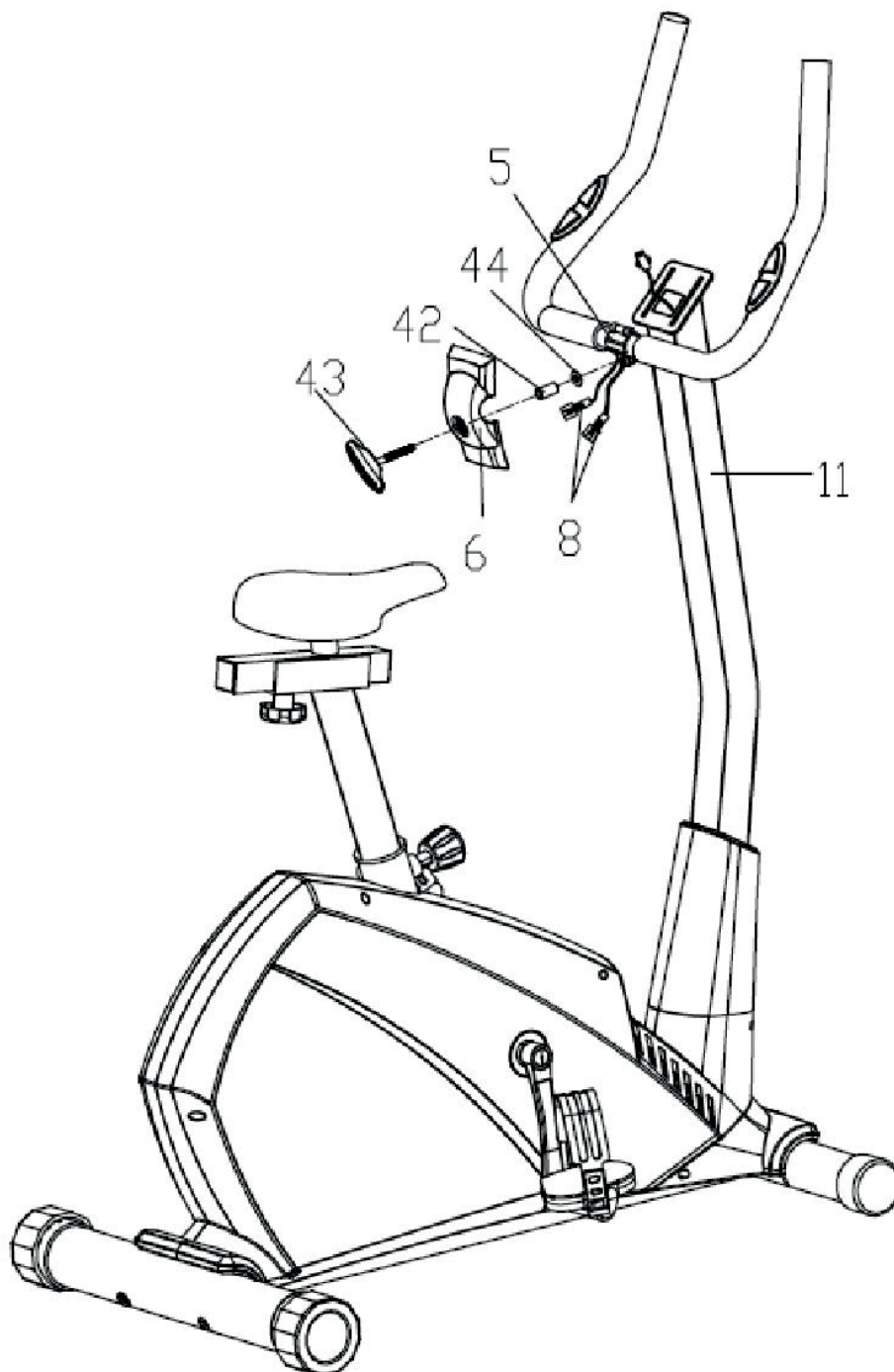

STEP 6

1. Connect all the wires (8 & 12) to the wires come from the computer (4), and then install the computer(4) onto the computer bracket on the top of the handlebar post (11), secured it with the cross screws (39) as shown.
2. Attach the rear handlebar cover (9) to the handlebar post (11), fit the front and rear covers (6 & 9) properly, and then secure them together with the cross screw (10) as shown.
3. Insert the bottle holder (45) to the handlebar post (11) with cross tapping screw (46) and flat washer (47)

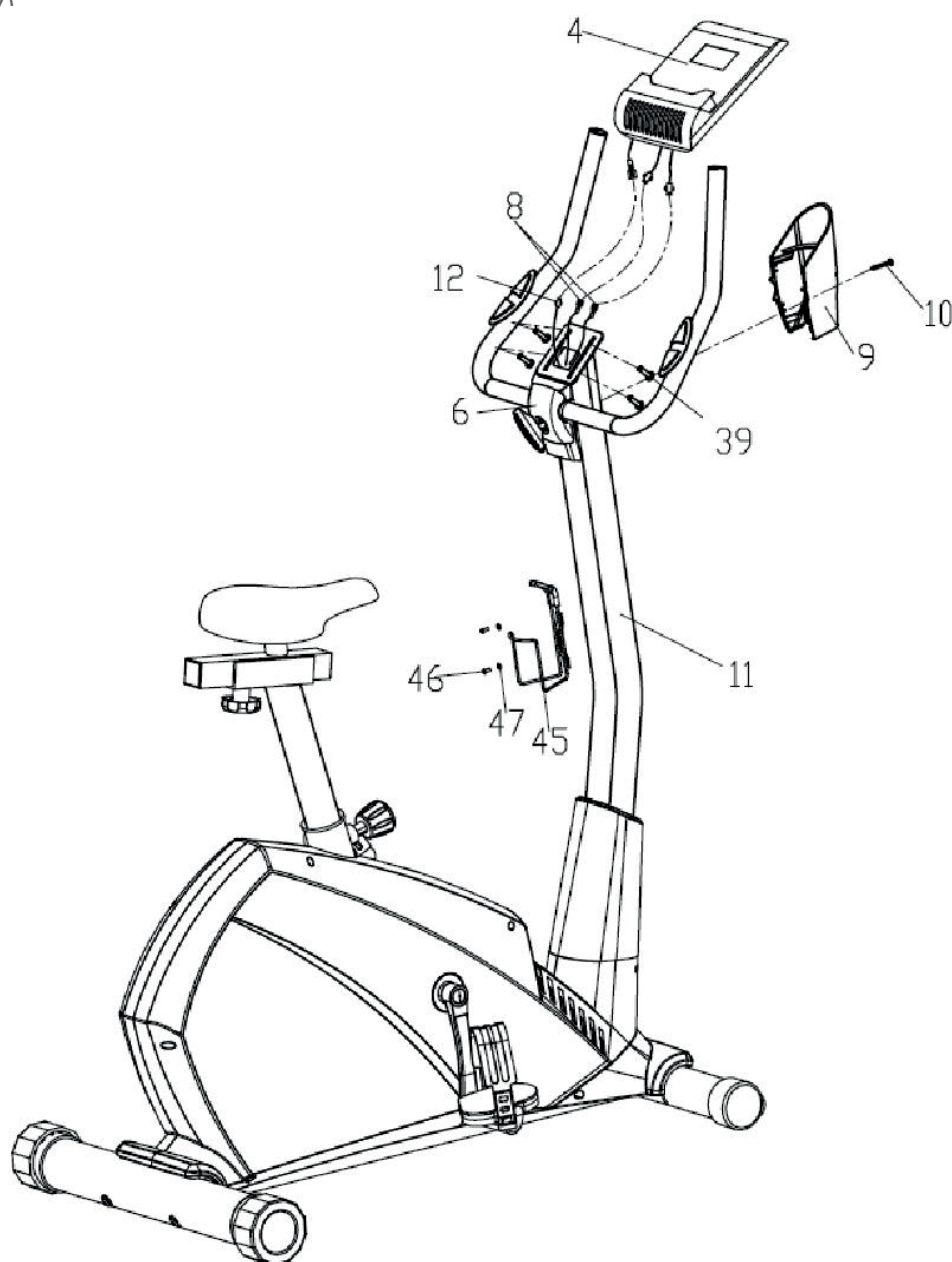

The hometrainer is now ready for use!

How to adjust the height and the horizontal position of the saddle

To be able to train effectively, the saddle must be at the correct height. During stairs, your knees must be slightly bent when the pedals are in the lowest position. To adjust the height of the saddle, first release the seat post button. Pull the knob towards you, slide the seat post up or down to the desired position and release the knob. Move the seat post slightly up or down to make sure that the button is in the seat post in one of the adjusting holes. Then tighten the button. To adjust the horizontal position of the saddle, first release the saddle button a few turns. Then slide the saddle forward or back into the desired position and firmly tighten the saddle.



How to adjust the angle of the handles

To adjust the angle of the handles, loosen the button and put the handles in the desired position. Then retighten the handles by turning the knob.

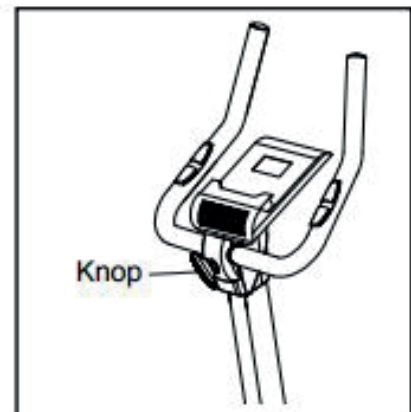

How to adjust the footrests

To adjust the footrests, first pull the ends of the footrests apart from the lips on the pedals. Adjust the footrests to the desired position and then tighten the ends of the footrests on the lips.

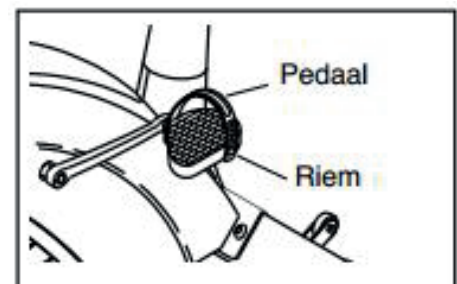

FUNCTIONS

START/STOP:

1. Start & Pauses workouts.
2. Start body fat measurement.
3. Operates only when in stop mode. Holding key for 3 seconds will reset all function value to be zero.

DOWN:

Decrease value of selected workout parameter: TIME, DISTANCE, etc. During the workout, it will decrease the resistance load.

UP :

Increases value of selected workout parameter. During the workout, it will increase the resistance load.

ENTER:

To input desired value or work out mode.

TEST(PULSE , RECOVERY):

Press to enter into Recovery function when computer has the heart rate value. Recovery is Fitness Level 1-6 after 1 minute. F1 is the best, and F6 is the worst.

MODE:

Press to switch display form RPM to SPEED, ODO to DIST , WATT to Calories during workout.

WORKOUT SELECTION

After power-up using UP or DOWN keys to select then pressing ENTER to enter the desired mode. After selecting your desired program, you may pre-set several workout parameters for desired results. WORKOUT PARAMETERS: TIME / DISTANCE / CALORIES / AGE

Note: Some parameters are not adjustable in certain programs.

Once a program has been selected, pressing ENTER, will make "Time" parameter flash. Using UP OR DOWN KEY you may select desired time value. Press ENTER KEY to input value. Flashing prompt will move to the next parameter. Continue use of UP OR DOWN KEY. Press START/STOP to start workout.

PROGRAMS

P1 Manual

Selecting "Manual" using UP OR DOWN KEY then pressing ENTER KEY. First parameter "Time" will flash so value can be adjusted using UP OR DOWN KEY. Press ENTER KEY to save value & move to next parameter to be adjusted. Continue through all desired parameters, pressing START/STOP to start workout.

Note: One of workout parameters counts down to be zero, it will have bi sounds and stop the workout automatically. Press START KEY to continue the workout to reach the unfinished workout parameter.

P2 - P14 Pre-programs

There are 10 program profiles ready for use. All program profiles have 24 level of resistance.

Selecting one of pre-programs using UP OR DOWN KEY then pressing ENTER KEY. First parameter "Time" will flash so value can be adjusted using UP OR DOWN KEY. Press ENTER KEY to save value & move to next parameter to be adjusted. Continue through all desired parameters, pressing START/STOP to start workout.

Note: One of workout parameters counts down to be zero, it will have bi sounds and stop the workout automatically. Press START KEY to continue the workout to reach the unfinished workout parameter.

P15 Watt control program

Selecting "Watt control program" using UP OR DOWN KEY then pressing ENTER KEY. First parameter "Time" will flash so value can be adjusted using UP OR DOWN KEY. Press ENTER KEY to save value & move to next parameter to be adjusted. Continue through all desired parameters, pressing START/STOP to start workout.

Note: One of workout parameters counts down to be zero, it will have bi sounds and stop the workout automatically. Press START KEY to continue the workout to reach the unfinished workout parameter. Computer will adjust the resistance load automatically depends on the speed to maintain the constant watt value. User can use up down key to adjust the watt value during workout.

P16 BODY FAT PROGRAM

Selecting "BODY FAT Program" using UP OR DOWN KEY then pressing ENTER. "Male " will flash so Gender can be adjusted using UP OR DOWN KEY, press ENTER to save gender & move to next data. "175" of Height will flash so Height can be adjusted to use UP OR DOWN KEY, press ENTER KEY save value & move to next data. "75" of Weight will flash so Weight can be adjusted to use UP OR DOWN KEY, press ENTER KEY to save value & move to next data. "30" of Age will flash so Age can be adjusted using UP OR DOWN KEY, press ENTER to save value.

Press START/STOP to start measurement, please also grasp hand pulse grips. After 15 seconds the display will show out Body Fat %, BMR, BMI & BODY TYPE.

NOTE:

Body Types: There are 9 body types divided according to the FAT% calculated. Type 1 is from 5% to 9%. Type 2 is from 10% to 14%. Type 3 is from 15% to 19%. Type 4 is from 20% to 24%. Type 5 is from 25% to 29%. Type 6 is from 30% to 34%. Type 7 is from 35% to 39%. Type 8 is from 40% to 44%. Type 9 is from 45% to 50%.

BMR: Basal Metabolism Ratio

BMI: Body Mass Index

Press START/STOP KEY to return the main display.

P17 TARGET HEART RATE Program

Selecting "TARGET H.R." using UP OR DOWN KEY then pressing ENTER KEY. First parameter "Time" will flash so value can be adjusted using UP OR DOWN KEY. Press ENTER KEY to save value & move to next parameter to be adjusted. Continue through all desired parameters, pressing START/STOP to start workout.

Note: If Pulse is above or below (± 5) the set TARGET H.R, computer will adjust the resistance load automatically. It will check every 10 seconds approx. The resistance load will increase or decrease. One of workout parameters counts down to be zero, it will have bi sounds and stop the workout automatically. Press START/STOP to continue the workout to reach unfinished workout parameter.

There are 3 selection for target pulse:

P15- 60% TARGET H.R= 60% of (220-AGE) P16- 75% TARGET H.R= 75% of (220-AGE) P17- 85% TARGET H.R= 85% of (220-AGE) Setting Parameters for HEART RATE CONTROL

Selecting "One of Heart Rate Control Program ." using UP OR DOWN KEY then pressing ENTER KEY. First parameter "Time" will flash so value can be adjusted using UP OR DOWN KEY. Press ENTER KEY to save value & move to next parameter to be adjusted. Continue through all desired parameters, pressing START/STOP to start workout.

Note: If Pulse is above or below (± 5) the TARGET H.R, computer will adjust the resistance load automatically. It will check every 10 seconds approx. The resistance load will increase or decrease. One of workout parameters counts down to be zero, it will have bi sounds and stop the workout automatically. Press START/STOP KEY to continue the workout to reach unfinished workout parameter.

P21-P24 USER PROGRAM

There are four user programs can be selected form U1 to U4.

User program allows user to set their own program that can be used immediately.

Setting Parameters for User Program

Selecting user using UP OR DOWN KEY then pressing ENTER KEY. First parameter "Time" will flash so value can be adjusted using UP OR DOWN KEY. Press ENTER KEY to save value & move to next parameter to be adjusted.

Continue through all desired parameters .

After finished set up desired parameter, the level 1 will flash, use UP OR DOWN KEY to adjust then pressing ENTER until finished. (There are 10 times total). Press START/STOP to start workout.

Note: One of workout parameters counts down to be zero, it will have bi sounds and stop the workout automatically. Press START/STOP KEY to continue the workout to reach unfinished workout parameter.

TRAINING INSTRUCTIONS

A successful exercise program consists of a warm-up, aerobic exercise, and a cool-down. Do the entire program at least two and preferably three times a week, resting for a day between workouts. After several months, you can increase your workouts to four or five times per week.

WARM-UP

The purpose of warming up is to prepare your body for exercise and to minimize injuries. Warm up for two to five minutes before strength-training or aerobic exercising. Perform activities that raise your heart rate and warm the working muscles. Activities may include brisk walking, jogging, jumping jacks, jump rope, and running in place.

STRETCHING

Stretching while your muscles are warm after a proper warm-up and again after your strength or aerobic training session is very important. Muscles stretch more easily at these times because of their elevated temperature, which greatly reduces the risk of injury. Stretches should be held for 15 to 30 seconds. **DO NOT BOUNCE.**



Toe touch



Inner thigh stretch

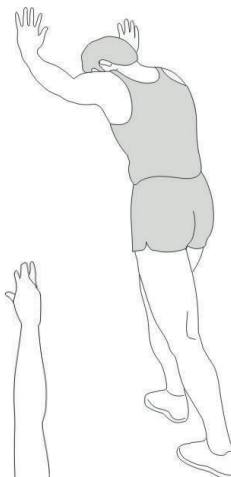

Achilles stretch



Hamstring stretch

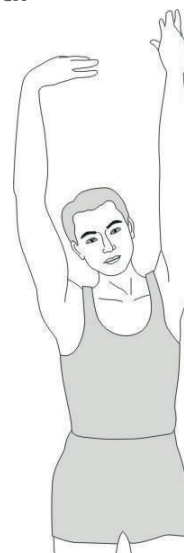

Side stretch

COOLING DOWN

The purpose of cooling down is to return the body to its normal or near normal, resting state at the end of each exercise session. A proper cool-down slowly lowers your heart rate and allows blood to return to the heart.

For questions or missing parts please contact Fitness Benelux:



Twekkelerweg 263
7553 LZ Hengelo
The Netherlands

T +31 (0)74-7600219
E service@fitnessbenelux.nl
W www.fitnessbenelux.nl